



USAID
FROM THE AMERICAN PEOPLE



MONTHLY PROGRESS REPORT NO. 04 JULY 2020

Architect-Engineer Independent Quality Assurance and Milestone Certification Services for USAID's Federally Administered Tribal Areas Infrastructure and Khyber Pakhtunkhwa Reconstruction Programs (A-E FIP KPRP)

This report is made possible by the support of the American people through the United States Agency for International Development (USAID). This document was produced by CDM International Inc. for review by USAID. The contents are the sole responsibility of CDM International Inc. and do not necessarily reflect the views of USAID or the United States Government.

Monthly Progress Report No. 04

July 2020

Architect-Engineer Independent Quality Assurance and Milestone Certification Services for USAID's Federally Administered Tribal Areas Infrastructure and Khyber Pakhtunkhwa Reconstruction Programs (A-E FIP KPRP)

Prepared by: Tahir Shamshad, Project Manager/Chief of Party

Organization: CDM International, Inc. (CDM Smith) in association with National Development Consultants (Pvt.) Ltd. and UNICON Consulting Services (Pvt.) Ltd. (UNICON)
39-D Sahibzad Abdul Qyum Road, University Town Peshawar Pakistan
Telephone: +92-917-247-900

Submitted to: Shahid Mahmood, United States Agency for International Development (USAID)
Task Order Contracting Officer's Representative (TOCOR)

USAID Contract No.: 72039I19D00005, Task Order 72039I20F00001

Report Date: 10 August 2020

VERSION HISTORY

VERSION	AUTHORED BY	REVISION DATE	APPROVED BY	APPROVAL DATE	REASON FOR REVISION
Draft Version	Tahir Shamshad	-	Keith F. Williams	-	Draft Issue
V-02	Tahir Shamshad	10 August 2020	Keith F. Williams	10 August 2020	Edits and formatting

TABLE OF CONTENTS

List of Annexes.....	ii
List of Tables.....	ii
List of Acronyms and Abbreviations.....	iii
I INTRODUCTION	1-1
1.1 PURPOSE OF THE MONTHLY PROGRESS REPORT.....	1-1
1.2 SUMMARY OF FIP AND KPRP.....	1-1
1.3 A-E FIP KPRP PROJECT DESCRIPTION.....	1-2
2 PROJECT ORGANIZATION	2-1
2.1 PROJECT STAFFING.....	2-1
2.2 SECURITY.....	2-3
3 MOBILIZATION ACTIVITIES.....	3-1
3.1 LIMITED NTP	3-1
3.2 KICKOFF MEETING.....	3-1
3.3 OBTAINING NOC OF FATA	3-1
3.4 OFFICE SPACE.....	3-1
3.5 ASSETS DISPOSITION PLAN	3-2
4 SUMMARY OF ACTIVE CONTRACTS AND MILESTONES.....	4-1
5 CONSTRUCTION QA AND MILESTONE CERTIFICATION ACTIVITIES	5-1
5.1 STATUS OF MILESTONES	5-1
5.2 STAKEHOLDER MEETINGS AND COORDINATION.....	5-2
5.3 CERTIFICATION VISITS	5-3
5.4 PERIODIC INSPECTIONS	5-4
5.5 PERIODIC TESTING OF MATERIALS.....	5-7
5.6 KEY ISSUES IDENTIFIED IN CONSTRUCTION QA AND MILESTONE CERTIFICATION SITE VISITS.....	5-7
5.7 VERIFICATION OF MILESTONES OF MSP JACOBABAD	5-8
5.8 INSPECTION OF ELECTRICAL MATERIAL SUPPLIES AT LAHORE - FIP ENERGY PROJECTS	5-8
6 DESIGN QA ACTIVITIES	6-1
7 ENVIRONMENTAL COMPLIANCE REPORTING	7-1
8 GENDER REPORTING	8-1
9 COVID-19 PANDEMIC IMPACT.....	9-1

List of Annexes

Annex A Active PILs and Projects Status

Annex B Organization Charts

Annex C Site Pictures

List of Tables

Table 2.1: Staff Mobilization Plan..... 2-1

Table 5.1: Summary of Milestones Certifications..... 5-1

Table 5.2: Summary of Total Site Visits for Milestone Certifications..... 5-3

Table 5.3: Summary of Site Visits for Periodic QA Inspections..... 5-4

Table 5.4: Key Issues and Recommendations (July 2020) 5-7

List of Acronyms and Abbreviations

A-E	Architect-Engineer
A-E FIP KPRP	Architect-Engineer Independent Quality Assurance and Milestone Certification Services for USAID’s Federally Administered Tribal Areas Infrastructure and
A-E TPM MSPKP	Architect-Engineer Services for Independent Third-Party Monitoring of the Municipal Services Program – Khyber Pakhtunkhwa
FATA	Federally Administered Tribal Areas
FIP	FATA Infrastructure Program
FR	Frontier Region
GOP	Government of Pakistan
G2G	Government-to-Government
GoKP	Government of Khyber Pakhtunkhwa
Halcrow	Halcrow Pakistan
IDIQ	Indefinite Delivery, Indefinite Quantity
IQA	Independent Quality Assurance
KP	Khyber Pakhtunkhwa
KPRP	Khyber Pakhtunkhwa Reconstruction Program
MCS	Milestone Certification Services
NOC	No Objection Certificate
NTP	Notice to Proceed
PaRRSA	Provincial Reconstruction, Rehabilitation, and Settlement Authority
PD	Project Director
P&D	Planning and Development
PIL	Project Implementation Letter
PMU	Project Management Unit
TESCO	Tribal Areas Electricity Supply Company
TDP	Temporarily Displaced Persons
QA	Quality Assurance
UNICON	UNICON Consulting Services (Pvt.) Ltd.
USAID	United States Agency for International Development

I INTRODUCTION

This Monthly Progress Report No. 04 for July 2020 is submitted for the Architect-Engineer Independent Quality Assurance and Milestone Certification Services for USAID's Federally Administered Tribal Areas Infrastructure and Khyber Pakhtunkhwa Reconstruction Programs (A-E FIP KPRP) task order, hereinafter referred to as "the Project," under USAID/Pakistan's Architect-Engineer Services Indefinite Delivery, Indefinite Quantity contract (A-E IDIQ). The Project is implemented by CDM International, Inc. (CDM Smith) and its subcontractors National Development Consultants (Pvt.) Ltd (NDC) and UNICON Consulting Services (Pvt.) Ltd (UNICON). USAID's limited notice to proceed (NTP) for activities related to Khyber Pakhtunkhwa Reconstruction Program (KPRP) projects was issued on March 2, 2020. CDM Smith obtained the No Objection Certificate (NOC) covering activities in the Federally Administered Tribal Areas (FATA) under FIP and the NTP for FIP activities is in process.

1.1 PURPOSE OF THE MONTHLY PROGRESS REPORT

The task order requires CDM Smith to submit monthly progress reports to USAID with a summary of activities and tasks undertaken during the month. Several ongoing and active contracts under the various project implementation letters (PILs) are in progress to advance USAID's FIP and KPRP. CDM Smith's team of quality assurance (QA) specialists, engineers, inspectors, and other support staff has been mobilized to carry out the required tasks under this contract to provide independent quality assurance (IQA) and milestone certification services (MCS). This monthly progress report also provides an update on the mobilization of staff to carry out the required tasks.

1.2 SUMMARY OF FIP AND KPRP

USAID is partnering with the Government of Pakistan (GOP) to rebuild essential services damaged by natural and man-made disasters over the past decades in Khyber Pakhtunkhwa (KP) and FATA. The programs are being implemented by different GOP divisions. Through the FIP and KPRP, USAID/Pakistan is committed to supporting Pakistan's journey to self-reliance by strengthening its delivery of improved infrastructure to rebuild essential services damaged by natural and man-made disasters in KP and FATA. This government-to-government (G2G) initiative is an ambitious \$200 million activity that empowers the GOP to improve infrastructure (roads, bridges, education facilities, health facilities, administrative buildings, drinking water supply, power transmission lines, grid stations, solarization of tube wells) through Project Management Units (PMUs). The FIP and KPRP are described below.

- **FATA Infrastructure Program:** The FIP is implemented by the FATA Secretariat. USAID signed the activity agreement for the program with the GOP on March 10, 2011, which was subsequently revised and amended for changes in scope, obligation of budget, and extension of the completion date. The FIP is implemented under a G2G mechanism through a PMU established by the GOP under the FATA Secretariat, and the PMU is headed by a project director (PD). The PMU has an established office in Peshawar and is accountable to a governing body - Program Steering Committee, which is headed by the Additional Chief Secretary, Government of Khyber Pakhtunkhwa (GoKP) Planning and Development Department.

Under the activity agreement, USAID is providing approximately \$100 million directly to the PMU-FIP to fund the architect-engineer (A-E) services, construction contracts, and equipment and machinery procurement. Approximately \$2.1 million has been disbursed through April 30, 2019.

The list of activities includes construction of roads, bridges, education facilities, health facilities, drinking water supply, power transmission lines, grid stations, and solarization of tube wells. The FIP has completed some activities, and other activities are underway. Infrastructure and construction activities in progress are detailed in **Annex A**. The construction works are at various stages.

- **Khyber Pakhtunkhwa Reconstruction Program:** KPRP is implemented by the GoKP's Provincial Reconstruction, Rehabilitation, and Settlement Authority (PaRRSA). The activity agreement for the program was signed with the GoKP on June 10, 2011 and was subsequently revised and amended for changes in scope, obligation of budget, and extension of the completion date. KPRP is implemented under a G2G mechanism through a PMU established by the GoKP under PaRRSA, and the PMU is headed by a PD. The PMU has an established office in Peshawar and is accountable to a governing body - Program Steering Committee, which is headed by the Director General PaRRSA.

Under the activity agreement, USAID is providing approximately \$100 million directly to the PMU-KPRP to fund the A-E services, construction contracts, and equipment and machinery procurement. Approximately \$70 million has been disbursed through April 30, 2019.

The list of activities includes construction of roads, education facilities, health facilities, administrative GoKP buildings, and drinking water supply. KPRP has completed some activities, and other activities are underway. Infrastructure and construction activities in progress are detailed in **Annex A**. The construction works are at various stages.

1.3 A-E FIP KPRP PROJECT DESCRIPTION

A-E FIP KPRP will provide IQA and MCS for quality oversight and technical guidance to bring the projects under the FIP and KPRP to successful completion and assure USAID/Pakistan that technical and contractual obligations of GoKP are fulfilled. As such, the project will provide A-E services to:

- a. Verify new construction sites and review assessments and site selection reports provided by the GOP.
- b. Review, verify, and recommend corrective steps and certify and vet the adequacy of all engineering designs and drawings provided by the GOP.
- c. Review bills of quantities, drawings, technical specifications, and engineer's estimate prepared by the GOP and provide recommendations to USAID on their reasonableness and realism.
- d. Verify payment milestones are in line with a logical construction sequence.
- e. Conduct periodic inspections and material testing at construction sites to ensure conformity to contract design, drawings, technical specifications, and other requirements, with reporting of any potential noncompliance with specifications and drawings.
- f. Review progress reports submitted by the GOP's implementing partners.
- g. Collect data and report data on program-relevant indicators in Pak-Info, USAID's online data reporting system.
- h. Undertake periodic sampling and testing of materials, develop testing frequency logs, and report failed tests to concerned parties for corrective action.
- i. Monitor progress of work against approved construction schedules, and report deviations and their causes and recommend corrective actions.
- j. Ensure as-built drawings are prepared and are accurate and complete.
- k. Prepare monthly progress reports with construction activity photos.

- l. Verify and certify payment milestone invoices to be reimbursed to GOP.
- m. Support the GOP for developing the Environmental Documentation Form and Environmental Mitigation and Monitoring Plan using the standard USAID format. Reporting on environmental compliance will be an integral part of all work plans, monthly progress reports, and final reports.
- n. Report on the GOP's compliance with USAID's branding and marking requirements.
- o. Perform other technical assistance activities, within the ceiling price established for this task order related to USAID programs in Pakistan, including Azad Jammu and Kashmir and Northern Areas, on an as-needed basis.

2 PROJECT ORGANIZATION

2.1 PROJECT STAFFING

CDM Smith’s organization chart for this task order is in **Annex A**. Our staff includes full and part-time staff shared with CDM Smith’s other USAID task orders in Pakistan, depending on the position. CDM Smith and its subcontractors NDC and UNICON initiated work on staff mobilization immediately after receiving the limited NTP but placed mobilization on hold, as per instructions received from USAID on March 21, 2020, to May 9, 2020. **Table 2.1** lists the staff to be mobilized for this task order, with actual mobilization dates for staff. Staff will be mobilized in a gradual and systematic manner so that the required staff mobilized quickly to facilitate initial start-up activities, followed by mobilization of all remaining and required staff, as per the project requirements. To increase efficiencies and provide cost savings, some staff is shared between A-E FIP KPRP and CDM Smith’s separate task order based in Peshawar for Architect-Engineer Services for Independent Third-Party Monitoring of the Municipal Services Program – Khyber Pakhtunkhwa (A-E TPM MSPKP).

Staff hiring remained on hold from March 20 to May 9, 2020, because of the COVID-19 pandemic. Hiring of FIP specific staff was pending due to NOC and subsequent NTP from USAID. Since NOC has been received and NTP by USAID is in process, CDM Smith is starting process for hiring on FIP positions.

SR #	Position	Name	Firm	Type ¹	Mobilization Date
1	Project Manager – Multi Sector	Tahir Shamshad	CDM Smith	LTL	16 March 20
2	Quality Assurance Specialist – Roads	Faiz ur Rehman	CDM Smith	LTL	12 April 20
3	Quality Assurance Specialist – Buildings	Salah ud-Din	CDM Smith	LTL	12 April 20
4	Quality Assurance Specialist – MEP	Muhammad Awais Ghumman	CDM Smith	LTL	1 June 20
5	Project Controls Specialist	Khurum Rauf	CDM Smith	LTL	2 March 20
6	Quantity Surveyor	Zafar Iqbal Tariq	CDM Smith	LTL	18 March 20
7	Construction QA Engineer – Roads	TBD	NDC	LTL	TBD ²
8	Construction QA Engineer – Roads	TBD	NDC	LTL	TBD
9	Construction QA Engineer – Buildings	Farman Ullah	UNICON	LTL	28 May 20
10	Construction QA Engineer – Buildings	Muhammad Sareer	UNICON	LTL	22 June 20
11	Construction Material Testing Lab Officer	Muhammad Nawaz	NDC	LTL	22 June 20
12	Finance/Procurement Specialist	Muhammad Naveed	CDM Smith	LTL	2 March 20
13	Accountant	Zahid Yousaf	CDM Smith	LTL	1 July 20
14	HR/Compliance Officer	Muhammad Irfan	CDM Smith	LTL	2 March 20
15	Operations & Security Manager	Maj Ijaz Ahmed	CDM Smith	LTL	1 June 20
16	Receptionist	Ms. Kulsum Zahir	CDM Smith	LTL	1 July 20
17	Office Engineer	TBD	UNICON	LTL	TBD
18	Driver	Said ur Rehman	CDM Smith	LTL	1 July 20
19	Driver	Muhammad Maqbool Hussain	CDM Smith	LTL	1 July 20
20	Driver	Sarfraz	CDM Smith	LTL	1 July 20
21	Driver	Shahzad Munsif	CDM Smith	LTL	1 July 20
22	Driver	Muhammad Zafar	CDM Smith	LTL	1 July 20

Table 2.1: Staff Mobilization Plan

SR #	Position	Name	Firm	Type ¹	Mobilization Date
23	Driver	Mehmood Awan	CDM Smith	LTL	1 July 20
24	Driver	TBD	CDM Smith	LTL	TBD
25	Office Boy	Anees Nasir	NDC	LTL	1 July 20
26	Project Coordinator	TBD	NDC	STL	TBD
27	Senior Civil Engineer	TBD	NDC	STL	TBD
28	Architect - 1	TBD	UNICON	STL	TBD
29	Architect - 2	TBD	UNICON	STL	TBD
30	CAD Operator - 1	TBD	UNICON	STL	TBD
31	CAD Operator - 2	TBD	NDC	STL	TBD
32	Civil Engineer – Roads	TBD	NDC	STL	TBD
33	Civil Engineer – Water/Sanitation	TBD	NDC	STL	TBD
34	Structural Engineer - I	TBD	UNICON	STL	TBD
35	Environmental Compliance Engineer	TBD	NDC	STL	TBD
36	Gender Specialist	TBD	NDC	STL	TBD
Mingora Office					
37	Senior Construction QA Engineer	Farooq Alam	CDM Smith	LTL	18 March 20
38	Construction QA Engineer – Roads & Infrastructure	M. Umer Farooq	NDC	LTL	22 June 20
39	Construction QA Engineer – Roads & Infrastructure	TBD	NDC	LTL	TBD
40	Construction QA Engineer – Buildings	TBD	UNICON	LTL	TBD
41	Construction QA Engineer – Buildings	TBD	UNICON	LTL	TBD
42	Construction QA Engineer – Buildings	TBD	UNICON	LTL	TBD
43	Construction Material Testing Lab Officer	Murad Hussain	NDC	LTL	2 July 20
44	Admin/Security Officer	TBD	CDM Smith	LTL	TBD
45	Office/Finance Manager	Muhammad Qaisar	CDM Smith	LTL	1 June 20
46	Driver	Mian Said Jaan Bacha	NDC	LTL	22 June 20
47	Driver	Akhtar Hussain	NDC	LTL	22 June 20
48	Driver	Muhammad Razzaq	NDC	LTL	22 June 20
49	Driver	TBD	NDC	LTL	TBD
50	Driver	TBD	NDC	LTL	TBD
51	Driver	TBD	NDC	LTL	TBD
52	Office Boy	TBD	NDC	LTL	TBD
Kurram Agency Office					
53	Junior Construction QA Engineer	TBD	CDM Smith	LTL	TBD
54	Construction QA Engineer – Roads & Infrastructure	TBD	NDC	LTL	TBD
55	Construction QA Engineer – Buildings	TBD	UNICON	LTL	TBD
56	Construction QA Engineer – Buildings	TBD	UNICON	LTL	TBD
57	Admin/Security Officer	TBD	CDM Smith	LTL	TBD
58	Office/Finance Manager	TBD	CDM Smith	LTL	TBD
59	Driver	TBD	NDC	LTL	TBD
60	Driver	TBD	NDC	LTL	TBD
61	Office Boy	TBD	NDC	LTL	TBD
DI Khan Office					
62	Construction QA Engineer	TBD	CDM Smith	LTL	TBD

Table 2.1: Staff Mobilization Plan					
SR #	Position	Name	Firm	Type ¹	Mobilization Date
63	Construction QA Engineer Buildings	TBD	UNICON	LTL	TBD
64	Construction QA Engineer – Electrical	TBD	NDC	LTL	TBD
65	Admin/Security Officer	TBD	CDM Smith	LTL	TBD
66	Office/Finance Manager	TBD	CDM Smith	LTL	TBD
67	Driver	TBD	NDC	LTL	TBD
68	Driver	TBD	NDC	LTL	TBD
69	Driver	TBD	NDC	LTL	TBD
70	Office Boy	TBD	NDC	LTL	TBD
Timirgarah Office					
71	Construction QA Engineer – Buildings	TBD	UNICON	LTL	TBD
72	Construction QA Engineer – Roads	TBD	NDC	LTL	TBD
73	Electrical Engineer	Shehryar Afridi (Currently stationed in Peshawar)	NDC	LTL	24 July 2020
74	Admin/Finance Officer	TBD	CDM Smith	LTL	TBD
75	Driver	TBD	NDC	LTL	TBD
76	Driver	TBD	NDC	LTL	TBD
77	Driver	TBD	NDC	LTL	TBD
78	Office Boy	TBD	NDC	LTL	TBD

¹ LTL = long-term local; STL = short-term local

² TBD = to be determined

2.2 SECURITY

CDM Smith included a security plan and budget with the cost proposal submitted to USAID on July 22, 2019. The security plan is implemented by the operations and security manager on the project team in coordination with the project manager. The project team will continue to work with the CDM Smith corporate health and safety department and with International SOS (security subcontractor) to develop the necessary security risk assessment.

CDM Smith’s hired security guards are performing duty at Peshawar, Timirgarah, Swat, and Dera Ismail Khan (DI Khan) offices.

3 MOBILIZATION ACTIVITIES

3.1 LIMITED NTP

The limited NTP was received from USAID on March 2, 2020, for projects under KPRP. NOC for FIP was received on July 30, 2020 and NTP for FIP is in process.

3.2 KICKOFF MEETING

Because the GOP imposed the COVID-19 lockdown, a formal kickoff meeting has not been conducted. CDM Smith expects to conduct a kickoff meeting with USAID and key stakeholders when conditions allow.

3.3 OBTAINING NOC OF FATA

CDM Smith submitted NOC request to FATA Secretariat on January 15, 2020. CDM Smith has followed the application's progress through various Pakistani government authorities and departments and continued working closely with them to obtain NOC to start working on FIP. NOC was received on July 30, 2020 and submitted to USAID to support the request for NTP. Below is a sequence of events for the month of July 2020.

On 28 June 2020, the authorities requested same documentation for CDM Smith's partners, UNICON and NDC as well as requested from CDM Smith. CDM Smith pursued Mr. Foad Hussain, CEO of NDC Pvt. Ltd and Mr. Pervaiz Qureshi, CEO of UNICON Pvt. Ltd for provision of required documents. Both gentlemen informed that the person who contacted them on phone for providing personal level information has been requested to write a formal letter to them. Both Sub Contractors of CDM Smith have contacted their legal advisers and stand with principal stance not to provide any documents as the same are not required as per Law.

On July 6, 2020, CDM Smith approached USAID to assist in communicating with the relevant Government Authorities to determine the way forward for issuance of the NOC. On July 15, 2020, USAID asked CDM Smith to approach the relevant authorities for further instructions. On July 17, 2020, CDM Smith's Manager Operations met with the relevant authority, who advised him to prepare a schedule for visits to FATA merged districts. The requested program was submitted to P&D the following day and P&D also forwarded the requisite information to TDP section on July 17, 2020. Thereafter, CDM Smith's Manager Operations visited relevant government offices, pursued the subsequent stages with relevant authority to expedite the approval. On July 20, 2020, CDM Smith received confirmation that case has been dispatched to Rawalpindi. Relevant authorities sent interim permission for CDM Smith visits to FATA and the case went back to TDP section and P&D KPK. CDM Smith received NOC on July 30, 2020 valid till January 23, 2020 with terms and conditions and renewable at the time of expiry.

3.4 OFFICE SPACE

Peshawar Staff House lease was extended up to June 30, 2020 for settlement of inventory. The inventory is moved to new office premises and staff house has been vacated and handed over to the property owner.

CDM Smith has leased long-term offices at Mingora, Timirgarah, and DI Khan for the project's duration. Peshawar and Mingora offices have been made operational utilizing existing inventory handed over by previous contractor to the extent possible.

Sorting of inventory stored in the newly hired offices is completed. A new list of remaining inventory is being prepared after utilization of inventory as much as possible keeping in view functional requirements. Necessary office furnishings (after utilizing in hand inventory), including computers,

copiers, printers, IT network, and office furniture are being procured. However, because of the COVID-19 limited working hours and restrictions, the required equipment procurement is in slow pace. The status of five offices is as follows:

1. **Peshawar Office:** Office is operational and necessary procurements are in progress
2. **Mingora Office:** Office is operational and necessary procurements are in progress
3. **Timirgarah Office:** Lease agreement has been signed with the owner of existing office location for one year. Inventory has been shifted to one floor. Office will be made operational upon issuance of NTP by USAID
4. **DI Khan Office:** Lease agreement has been signed with the owner of new office location for one year. Inventory has been shifted to new office location. Office will be made operational upon issuance of NTP by USAID
5. **Kurram Agency:** Selection and finalization was on hold due NOC to work on FIP. Office space will be leased, and office will be made operational upon issuance of NTP by USAID

3.5 ASSETS DISPOSITION PLAN

CDM Smith is utilizing existing assets as much as possible in office set up. Remaining assets disposition plan will be sent for USAID's approval after all offices are made operational. Upon approval, assets recommended to be retained by CDM Smith will be retained for this project and disposal of remaining items will be done (either handover to third-party or auction) as instructed by USAID.

4 SUMMARY OF ACTIVE CONTRACTS AND MILESTONES

Projects covered in the FIP and KPRP are in Buner, Dir, Swat, Malakand, Shangla, Nowshera, DI Khan, Peshawar, Charsadda, Orakzai, Kurram, Frontier Region (FR) Kohat, FR Peshawar, Khyber, Bajaur, Jandola, South Waziristan and Mohmand. All projects are approved under unique PILs, and each PIL includes one or several contracts. The list of active projects (activities) included in the FIP and KPRP for which A-E FIP KPRP will provide IQA and MCS is in **Annex A**.

5 CONSTRUCTION QA AND MILESTONE CERTIFICATION ACTIVITIES

5.1 STATUS OF MILESTONES

Following milestones were approved during July 2020:

Table 5.1: Summary of Milestones Certifications						
Sr. No.	Inspection Date	PIL #	Invoice Number	Milestone #	Description of Works	Certification Amount (USD)
1	June 30, 2020	32	FDS-119	M-13 # 5,6,7 LB & Dev # 1,5e	GGPS Bara Bandai	55,752
2	July 08, 2020	32	FDS-119	M4 H # 3 M6 H # 5	GHS Swegalai (Swat)	40,418
3	July 02, 2020	32	FDS-119	LB & Dev # 1	GPS Balat (Swat)	5,248
4	July 02, 2020	32	FDS-119	T-7 # 2 LB & Dev # 1	GPS Chatoria (Swat)	14,880
5	July 02, 2020	32	FDS-119	T-7# 2	GPS Fatima (Swat)	8,429
6	July 02, 2020	32	FDS-119	T-3 # 2	GPS Pansat (Swat)	19,459
7	July 02, 2020	32	FDS-119	LB & Dev # 5a	GPS Shofin (Swat)	7,430
8	July 01, 2020	32	FDS-119	LB & Dev # 1	GPS Hawaii (Nowshetra)	4,072
9	July 01, 2020	32	FDS-119	M-3# 4,5 LB & Dev # 2	GPS Toha (Nowshetra)	43,090
10	July 01, 2020	36	FDS-120	M-7 # 1	GHSS No. 1 Nowshetra Kalan	14,252.40
11	June 24, 2020	36	FDS-120	M-7 # 1	GGPS Panam Dari	14,252
12	June 24, 2020	36	FDS-120	LB & Dev # 1	GPS Yari Koroona	3,258
13	July 02, 2020	36	FDS-120	T-7 # 4,5	GGPS Look Maira	18,054
14	July 08, 2020	36	FDS-120	T-4 # 1	GGPS Kalagay	16,721
15	July 08, 2020	36	FDS-120	M-13 # 4	GGPS Shah Dherai	15,296
16	July 08, 2020	36	FDS-120	U Shape # 1,2	GHS Matiltan	68,550
17	July 09, 2020	36	FDS-120	U Shape # 2	GHS Utror	30,845
18	July 08, 2020	36	FDS-120	M-13 # 3	GPS Matiltan	11,301
19	July 01, 2020	36	FDS-120	T-3 # 2	GPS Pir Patay Qalagai	15,567
20	June 30, 2020	36	FDS-120	M-13A # 4 M-13B # 2 M-11 # 2	GGHS No. 1 Mingora	43,331

Table 5.1: Summary of Milestones Certifications						
Sr. No.	Inspection Date	PIL #	Invoice Number	Milestone #	Description of Works	Certification Amount (USD)
21	June 30, 2020	36	FDS-120	M-13 # 1,2	GGPS Naway Kalay	34,433
22	July 08, 2020	36	FDS-120	LB (H)& Dev # 5b	GHS Jan Bhatti	22,272
23	July 09, 2020	36	FDS-120	M-2 # 1	GPS Gulzada Kalay	5,544
24	July 06, 2020	36	FDS-120	U-Shape # 2	GGCMHS Thana	27,345

Other than above, four vouchers for milestone certifications on KPRP were received on July 24, 2020 and are in process with CDM Smith. FIP milestone certification data and progress will also be brought into reporting from next month.

5.2 STAKEHOLDER MEETINGS AND COORDINATION

Details of meetings and teleconferences conducted with stakeholders during the reporting month are as follows.

1. A coordination meeting was held amongst CDM Smith and Global Consultants on July 01, 2020 at the CDM Smith's office in Peshawar, to discuss the requirement and provision of construction schedules, QA/QC Plan of Global and material test reports.
2. Joint site walkthrough and a coordination meeting was held on July 03, 2020 at GPS Balogram, Swat under PIL 36 by the Implementing and Executing authorities along with the end users and local government authorities. There was issue regarding the scope deletion of module M13 C which was jointly reviewed. After complete review and layout, it was agreed between all stakeholders to continue with the revised module for M13 C and that the buildings should be constructed to serve the need of the school management. Implementing authorities will further update USAID on agreed proposal for execution of works.
3. A meeting was held amongst PU C&W, CDM Smith and Global Consultants on July 09, 2020 to review the snags lists of completed schools in Nowshera. After verification of rectified snags by the consultant, Final Inspection Reports of GPS Khan Jan Kalay, GPS Zakhi Qabristan were jointly signed by all stakeholders.
4. A coordination meeting was held at WSSC office Swat along with DD PU PaRRSA Planning and CDM Smith for the review of proposal submitted by PaRRSA for DWSS Barama under PIL 25.
5. Monthly Coordination Meeting was held between CDM Smith Team and COR-USAID on July 16, 2020 via video conferencing. Program status and issues were discussed in detail.
6. Progress review meeting regarding ongoing flood damaged schools under KPRP was held amongst PaRRSA, PU C&W, CDM Smith & Global under the chairmanship of Project Director PU C&W on July 17, 2020 at PU C&W office in Peshawar.
7. A coordination meeting was held between CDM Smith, PaRRSA, PU C&W and M/s Global Consultant at PDMA-PaRRSA Office Swat on July 23, 2020. CDM Smith's COP Mr. Tahir Shamshad met with the stakeholders for introduction and review of program developments.

8. Coordination Meeting was held between CDM Smith and DDs C&W Building works on July 29, 2020 for upcoming milestone verification schedule and site work status considering the upcoming EID holidays.

5.3 CERTIFICATION VISITS

Field visits to verify/certify the claimed milestones during the reporting month are shown in **Table 5.2**.

Table 5.2: Summary of Total Site Visits for Milestone Certifications			
Sr. No.	Inspection Date	PIL #	Description of Works
1	July 01, 2020	32	GPS Toha
2	July 01, 2020	32	GPS Hawaii
3	July 01, 2020	36	GHSS Nowshera Kalan
4	July 01, 2020	36	GGPS Shah Dherai
5	July 01, 2020	36	GGPS Pir Patay Qalagai
6	July 02, 2020	32	GPS Pansat
7	July 02, 2020	32	GPS Balat
8	July 02, 2020	36	GPS Talkar
9	July 02, 2020	32	GPS Chatoria
10	July 02, 2020	36	GPS Showfin
11	July 02, 2020	36	GPS Kandowgai Gut
12	July 02, 2020	36	GPS Fatima
13	July 06, 2020	36	GGCMHS Thana
14	July 08, 2020	36	GGPS Kalagay
15	July 08, 2020	36	GHS Matiltan
16	July 08, 2020	36	GPS Matiltan
17	July 08, 2020	36	GHS Jan Bhatti
18	July 09, 2020	36	GHS Utror
19	July 09, 2020	36	GPS Gulzada Kalay
20	July 22, 2020	41	TESCO Store, Hayatabad
21	July 27, 2020	36	GGPS Shah Dherai
22	July 27, 2020	36	GGPS Kemyari
23	July 27, 2020	36	GPS Dardyal
24	July 27, 2020	36	GGPS Chur Dardyal
25	July 27, 2020	36	GGPS Bara Samai

Table 5.2: Summary of Total Site Visits for Milestone Certifications			
Sr. No.	Inspection Date	PIL #	Description of Works
26	July 27, 2020	28	GGHS Manai
27	July 28, 2020	32	GHS Islampur
28	July 28, 2020	32	GPS Daro Maira
29	July 28, 2020	36	GGPS Khawr Kotay Qalagai
30	July 28, 2020	36	GPS Qala Qalagai
31	July 28, 2020	30	GPS Yarak No.01
32	July 28, 2020	30	GPS Jhoke Umaray Wali

5.4 PERIODIC INSPECTIONS

Periodic and final inspection site visits were conducted during the reporting month as shown in **Table 5.3**.

Table 5.3: Summary of Site Visits for Periodic QA Inspections			
Sr. No.	Inspection Date	PIL #	Description of Works
1	July 1, 2020	39	Baz Khela to Gal Shah Road
2	July 1, 2020	39	Sakhra Dispensary to Amlooko Road
3	July 6, 2020	32	GHS Pahtun Garhi
4	July 6, 2020	NA	DWSS Manki Sharif (to verify O&M Status)
5	July 6, 2020	NA	DWSS Madina Colony (to verify O&M Status)
6	July 7, 2020	NA	Spina Khpa Road UC Bara Durush Khela (1 km) PC-1
7	July 7, 2020	36	GGPS Naway Kalay
8	July 7, 2020	36	GGHS No. 1 Mingora
9	July 7, 2020	36	GPS Balogram
10	July 8, 2020	32	GHSS Akbar Pura
11	July 8, 2020	32	GHS Pahtun Garhi
12	July 8, 2020	36	GPS Ushu
13	July 9, 2020	NA	DWSS Armour colony (to verify O&M Status)
14	July 9, 2020	NA	DWSS Badrashi Eidah
15	July 13, 2020	32	GGPS Aman Kot
16	July 13, 2020	28	GGPS Maroba
17	July 13, 2020	32	GPS Khan Jan Kalay

Table 5.3: Summary of Site Visits for Periodic QA Inspections			
Sr. No.	Inspection Date	PIL #	Description of Works
18	July 14, 2020	36	GPS No.01 Katozai
19	July 14, 2020	36	GGPS Sadar Garhi
20	July 14, 2020	36	GHS Khesghi Bala
21	July 14, 2020	25	DWSS Barama
22	July 14, 2020	25	Hand Pump # 80 at Chail Shagai
23	July 15, 2020	36	GGPS Panam Dheri
24	July 15, 2020	36	GPS Yari Koroona
25	July 15, 2020	30	GPS Sundarai
26	July 15, 2020	30	GPS Zakaria
27	July 15, 2020	32	GPS Loye Namal
28	July 15, 2020	32	GPS Dughlai
29	July 15, 2020	32	GPS Talkar
30	July 15, 2020	32	GPS Balat
31	July 15, 2020	32	GPS Shofin
32	July 15, 2020	32	GPS Pansat
33	July 16, 2020	36	GHS Masho Khel
34	July 16, 2020	36	GPS No.02 Maira Balarzai
35	July 16, 2020	36	GHS Matani
36	July 16, 2020	36	GHS Jan Bhatti
37	July 16, 2020	30	GPS Zaimdara
38	July 16, 2020	9	GHS Maindan Bandai
39	July 16, 2020	28	GPS Muraday
40	July 16, 2020	32	GPS Fatima
41	July 16, 2020	28	GGPS Sarai Gut
42	July 16, 2020	32	GPS Shandal
43	July 16, 2020	32	GPS Chatoria
44	July 16, 2020	32	GPS Kandowgai Gut
45	July 20, 2020	39	Bar Gujar Banr Road (2 Km)
46	July 20, 2020	39	Gujar Banr Awi Shah Road (1.75 Km)
47	July 20, 2020	39	Bar Gujar Banr Road (2 Km)

Table 5.3: Summary of Site Visits for Periodic QA Inspections			
Sr. No.	Inspection Date	PIL #	Description of Works
48	July 21, 2020	28	GGPS Shalmano Kotkay
49	July 21, 2020	39	Bazkhela to Gal Shah Road (1.15 Km)
50	July 21, 2020	39	Sakhra Dispensary to Amloko Road (0.9 Km)
51	July 21, 2020	39	Shokh Dara Deran Patay Road (1.3 Km)
52	July 22, 2020	30	GHS Shang
53	July 22, 2020	30	GMS Bilkani
54	July 22, 2020	36	GGPS Kamyari
55	July 22, 2020	36	GPS Dardyal
56	July 22, 2020	36	GGPS Chur Dardyal
57	July 22, 2020	36	GPS Yari Koroona
58	July 22, 2020	36	GGPS Panam Dheri
59	July 22, 2020	36	GGPS Bara Samai
60	July 22, 2020	28	GHSS Manai
61	July 23, 2020	39	Flood Protection Wall at River Swat Mingora
62	July 23, 2020	32	GHS Swegalai (General site visit by COP)
63	July 23, 2020	29	Judicial Complex Kabal
64	July 23, 2020	28	GHS Pashtoon Gari
65	July 23, 2020	28	GHSS Akbarpoora
66	July 27, 2020	38	DWSS Kingergalai
67	July 27, 2020	38	DWSS Jowar No 2
68	July 28, 2020	38	DWSS Ghurghushto
69	July 28, 2020	38	Online Monitoring System
70	July 28, 2020	36	GGPS Panam Dheri
71	July 28, 2020	36	GPS Yari Korona
72	July 28, 2020	30	GPS Bairoon Sharqi
73	July 29, 2020	9	GHS Maidan Bandai
74	July 29, 2020	30	GGPS Kass
75	July 29, 2020	32	GHSS Akbar Pura

5.5 PERIODIC TESTING OF MATERIALS

Material testing labs have been established in Peshawar and Mingora offices and testing of materials has commenced. Below is a summary of tests conducted in both Labs.

Material Testing Lab Peshawar

Total Tests conducted: 27

Passed: 17

Failed: 10

Material Testing Lab Mingora

Total Tests conducted: 17

Passed: 15

Failed: 02

Failed test reports are being analyzed and evaluated/ retested by CDM Smith. Results found failed after re-analysis will be communicated to relevant department for necessary action with a copy to USAID for information.

5.6 KEY ISSUES IDENTIFIED IN CONSTRUCTION QA AND MILESTONE CERTIFICATION SITE VISITS

Table 5.4 includes common issues observed during site visits and proposed remedial actions. Site specific issues are being reported regularly through weekly update.

Table 5.4: Key Issues and Recommendations (July 2020)			
Sr. No.	Issue	Recommendation	Corrective Action Status
1.	Design documents including revisions, construction schedules, visitor log etc are not being maintained on site	Approved drawings, specification, construction schedule, RFI log, visitor log shall be maintained on site and regularly updated	New FVR template covers this issue and will be shared with USAID for necessary action
2.	Workmanship is an issue noted uniformly on almost all site	Engagement of rightly skilled workforce and better-quality control is required to improve workmanship	An issue log is introduced to document all workmanship related issues and IP's are expected to enforce measures necessary measures
3.	Response to contractors' queries on design and construction related issues are not being dealt on priority	First priority shall be to respond to contractor's RFI's and other site related issues so that the progress of work does not get interrupted	New FVR template covers this issue and will be shared with USAID for necessary action
4.	Frequency of visits to sites by IP's is not enough to timely intervene issues halting progress	Sites exhibiting slow progress shall be visited frequently by IP's to address issues and facilitate catching up with schedule	

Table 5.4: Key Issues and Recommendations (July 2020)			
Sr. No.	Issue	Recommendation	Corrective Action Status
5.	It is observed in general that MEP works are staying behind or lacking proper planning and workmanship. Completing MEP works late and modifications to complete MEP works is increasing level of effort/ affecting the quality of finishes	Better planning of work is required to avoid damaging walls and structural elements for MEP related works after completion of civil works	

5.7 VERIFICATION OF MILESTONES OF MSP JACOBABAD

Milestones Verification visit has been completed and 5 out of ten milestones have been certified. Remaining five milestones are on hold till provision of requested information from Sindh MSP. Certification for remaining milestones will be issued upon completion of highlighted outstanding works and provision of requested documentation.

5.8 INSPECTION OF ELECTRICAL MATERIAL FOR 132 KV GRID STATION JANDOLA

CDM Smith was directed by USAID to perform desk study of IPC# 2 for 132kV Grid Station Jandola under PIL 41. CDM Smith performed desk study, coordinated with TESCO and Cameos for additional documentation and visited TESCO store in Hayatabad Peshawar to verify delivery of electrical material. Milestone for electrical procurement component was not certified due to incomplete procurement covered under the claimed milestone. CDM Smith responded to USAID on July 30, 2020 and assignment was closed till further instructions from USAID.

6 DESIGN QA ACTIVITIES

No new design documents were received from USAID for design QA during the month of July 2020.

7 ENVIRONMENTAL COMPLIANCE REPORTING

No environmental specialist has been hired to date, so no environmental compliance reporting is available for July 2020.

8 GENDER REPORTING

No gender specialist has been hired to date, so no gender reporting is available for July 2020.

9 COVID-19 PANDEMIC IMPACT

With gradual relaxation of the lockdown beginning in mid-April, CDM Smith has started limited activities with attention to health and safety protocols. The following activities are currently being performed in limited and controlled manner with consideration to COVID-19 protocols.

1. Staff hiring
2. Periodic and milestones certification site inspections
3. Procurements

ANNEXES

Annex A Active PILs and Projects Status

Architect-Engineer Independent Quality Assurance and Milestone Certification Services for USAID's Federally Administered Tribal Areas Infrastructure and

Khyber Pakhtunkhwa Reconstruction Programs (A-E FIP KPRP)

Khyber Pakhtunkhwa Reconstruction Programs (KPRP) - List of Projects

As of July 31, 2020

**Progress (%age) updated as per the field visit conducted by CDM Smith's team

S.No	Project Description	District	PIL/FARA	Date of Work order	July 31, 2020 Progress (%age)	Status
1	GPS Inzer Maira No.1	Buner	FARA-I	1/7/2016	100.00%	Completed
2	GGPS Gumbatai	Dir Lower	FARA-II			Not yet started
3	GGPS Tarokay	Swat	PIL-09			Not yet started
4	GHS Maidan Bandai	Dir Lower	PIL-09	13-10-2016	100%	Completed
5	DWSS Barama	Swat	PIL-25	9/5/2014	92.50%	Work stopped
6	DWSS Shahidabad Fizagat	Swat	PIL-25	9/5/2014	91.76%	Work stopped
7	Installation of 120 hand Pumps	Swat	PIL-25	9/5/2014	63.00%	Work stopped
8	GGPS Serai Gut	Swat	PIL-28	18-7-2016	65.00%	Work stopped
9	GPS Muraday	Swat	PIL-28	20-6-2016	80.00%	Work stopped
10	GHSS Manai	Swat	PIL-28	22/03/2019	60.00%	In Progress
11	GPS Hisar Baba	Malakand	PIL-28	3/5/2016	88.30%	In Progress
12	GGPS Qambari	Shangla	PIL-28	3/5/2016	100.00%	Completed
13	GGPS Shalmano Kotkay	Shangla	PIL-28	9/6/2016	65.00%	In Progress
14	GHS Mian Brangola	Dir Lower	PIL-28	13-10-2016	75.20%	Work Stopped
15	GPS No. 1 Mishak	Nowshehra	PIL-28	6/22/2016	75.00%	In Progress
16	GGPS Marooba	Nowshehra	PIL-28	6/26/2016	75.00%	in Progress
17	GGPS Jhoke Gumla	DI Khan	PIL-28	4/20/2016	100.00%	Completed
18	GPS Jhoke Umaray Wali	DI Khan	PIL-28	4/20/2016	97.00%	In Progress
19	GPS Bairoon Sharqi	DI Khan	PIL-28	4/20/2016	95.00%	In Progress
20	Judicial Complex Building	Swat	PIL-29	26-4-2016	80.00%	In Progress
	District Government Building	Swat	PIL-29		67.00%	In Progress
	Line Department Offices Building	Swat	PIL-29		0.00%	Not yet started
	Jirga Hall	Swat	PIL-29		0.00%	Not yet started
	CAT-B Residence No. 1	Swat	PIL-29	24-05-2016	70%	In Progress
	CAT-B Residence No. 2	Swat	PIL-29		72%	In Progress
	CAT-B Residence No. 3	Swat	PIL-29		72%	In Progress
	CAT-B Residence No. 4	Swat	PIL-29		67%	Work stopped
	CAT-B Residence No. 5	Swat	PIL-29		68%	Work stopped
	CAT-B Residence No. 6	Swat	PIL-29		52%	In Progress
	CAT-B Residence No. 7	Swat	PIL-29		54%	In Progress
	CAT-B Residence No. 8	Swat	PIL-29		55%	In Progress
	CAT-B Residence No. 9	Swat	PIL-29		54%	In Progress
	CAT-B Residence No. 10	Swat	PIL-29		62%	In Progress
	Servant Quarter Building	Swat	PIL-29	2.78%	Work stopped	
	Boundary Wall	Swat	PIL-29	27%	Work stopped	
	Tube Well No. 1	Swat	PIL-29	90%	Work stopped	
	Tube Well No. 2	Swat	PIL-29	0%	Not yet Started	
	Over Head Water Tank (10,000 Gallons) No. 1	Swat	PIL-29	7%	In Progress	
	Over Head Water Tank (10,000 Gallons) No. 2	Swat	PIL-29	0%	Not yet Started	
External Road	Swat	PIL-29	10%	In Progress		
Watch Tower No. 1	Swat	PIL-29	0%	Not yet Started		
Watch Tower No. 2	Swat	PIL-29	0%	Not yet Started		
External Sewerage System (Septic Tanks, Soakage Pits)	Swat	PIL-29	0%	Not yet Started		
Man Holes	Swat	PIL-29	0%	Not yet Started		
Surface Drainage system	Swat	PIL-29	0%	Not yet Started		
External Electrification	Swat	PIL-29	0%	Not yet Started		
21	GPS Chinda Khora	Swat	PIL-30	12/7/2016	95.00%	Work in Progress
22	GGPS Kass	Swat	PIL-30	2/8/2016	100.00%	Completed
23	GHS Shang	Shangla	PIL-30	13-10-2016	68.17%	In progress
24	GMS Bilkanai	Shangla	PIL-30	3/5/2016	75.00%	In Progress
25	GGPS Begumar Lahore	Shangla	PIL-30	3/5/2016	100.00%	Completed
26	GHS Amnavi	Shangla	PIL-30	13-10-2016	50.00%	In Progress
27	GPS Zaimdara	Dir Lower	PIL-30	28-9-2016	100.00%	Completed
28	GHS Mirgam Bala	Dir Lower	PIL-30	10/11/2019	30.00%	In Progress
29	GMS Asigi Kalay	Dir Lower	PIL-30	5/10/2016	62.50%	In progress
30	GPS Shomnai	Dir Upper	PIL-30	24-11-2017	20.00%	Work stopped
31	GPS Zakria	Dir Upper	PIL-30	7/11/2016	100.00%	Completed
32	GPS Sundrai	Dir Upper	PIL-30	17-01-2017	100.00%	Completed
33	GPS No.1 Yarak	DI Khan	PIL-30	4/20/2016	98.08%	In Progress
34	GGPS Bara Bandai	Swat	PIL-32	18/3/2016	78.00%	In Progress
35	GHS Islampur	Swat	PIL-32	19-9-2017	55.00%	In Progress
36	GHS Swegalai	Swat	PIL-32	22/03/2019	60.25%	In Progress
37	GPS Balat	Swat	PIL-32	23-10-2017	37.00%	In Progress
38	GPS Chatoria	Swat	PIL-32	28-10-2017	35.00%	In Progress
39	GGPS Daro Maira	Swat	PIL-32	23-10-2017	64.50%	In Progress
40	GPS Dughlai	Swat	PIL-32	28-10-2017	18.00%	In Progress
41	GPS Fatima	Swat	PIL-32	23-10-2017	15.00%	In Progress
42	GPS Kandowgai Gut	Swat	PIL-32	23-10-2017	23%	In Progress
43	GPS Loye Namal	Swat	PIL-32	19-09-2017	30.00%	In Progress
44	GPS Mailaga	Swat	PIL-32	23-10-2017	30.00%	In Progress
45	GPS Pansat	Swat	PIL-32	23-10-2017	35.00%	In Progress
46	GPS Shandal	Swat	PIL-32	19-09-2017	45.00%	In Progress
47	GPS Shofin	Swat	PIL-32	23-10-2017	55.00%	In Progress
48	GPS Talkar	Swat	PIL-32	26-09-2017	45.00%	In Progress
49	GPS Zakhi Qabristan	Nowshehra	PIL-32	11/15/2017	100.00%	Completed

Architect-Engineer Independent Quality Assurance and Milestone Certification Services for USAID's Federally Administered Tribal Areas Infrastructure and

Khyber Pakhtunkhwa Reconstruction Programs (A-E FIP KPRP)

Khyber Pakhtunkhwa Reconstruction Programs (KPRP) - List of Projects

As of July 31, 2020

**Progress (%age) updated as per the field visit conducted by CDM Smith's team

S.No	Project Description	District	PIL/FARA	Date of Work order	July 31, 2020 Progress (%age)	Status
50	GPS No 1 Jaroba	Nowshehra	PIL-32	11/15/2017	100.00%	Completed
51	GPS Khan Jan Kalay	Nowshehra	PIL-32	11/15/2017	100.00%	Completed
52	GPS No 1 Mohalla Mula Khan	Nowshehra	PIL-32	11/15/2017	100.00%	Completed
53	GGPS Aman Kot	Nowshehra	PIL-32	11/15/2017	88.00%	In Progress
54	GHS Pashtoon Ghari	Nowshehra	PIL-32	11/15/2017	55.00%	In Progress
55	GPS Hawai	Nowshehra	PIL-32	11/15/2017	65.00%	In Progress
56	GPS Toha	Nowshehra	PIL-32	11/15/2017	65.00%	In Progress
57	GHSS Akbarpura	Nowshehra	PIL-32	9/19/2016	62.50%	In Progress
58	Ophthalmology	Swat	PIL-35		93.7%	In Progress
	Medicine	Swat	PIL-35		17.9%	In Progress
	General & Plastic Surgery + Anesthesia Department	Swat	PIL-35		17.4%	In Progress
	ENT	Swat	PIL-35		9.0%	In Progress
	Cardiology	Swat	PIL-35		78.7%	In Progress
	Obstetrics & Gynaecology	Swat	PIL-35		47.7%	In Progress
	Pathology	Swat	PIL-35		0.0%	In Progress
	Pediatrics	Swat	PIL-35		8.0%	In Progress
	Radiology	Swat	PIL-35		54.2%	In Progress
Dental	Swat	PIL-35		21.8%	In Progress	
	Casualty (Ambulances – 25 Nos.)	Swat	PIL-35		0.0%	Tendering process completed while PO not yet issued.
59	GGPS Bara Samai	Swat	PIL-36	9/4/2018	20.00%	In Progress
60	GGPS Chur Dardyal	Swat	PIL-36	11/14/2018	35.00%	In Progress
61	GGPS Kemyari	Swat	PIL-36	26-3-2018	18.37%	Work Stopped
62	GGPS Khwar Kotay Qalagai	Swat	PIL-36	9/4/2018	30.00%	In Progress
63	GGPS Look Maira	Swat	PIL-36	20-12-2018	65.00%	In Progress
64	GGPS Kalagay	Swat	PIL-36	26-3-2018	10.00%	In Progress
65	GGPS Shah Dherai	Swat	PIL-36	26-3-2018	40.00%	In Progress
66	GHS Matiltan	Swat	PIL-36	22-03-2019	30.00%	In Progress
67	GHS Utror	Swat	PIL-36	22-03-2019	30.00%	In Progress
68	GPS Bahadar Banda	Swat	PIL-36	3/28/2018	0.00%	Work Order Issued, Work Not yet Started
69	GPS Balogram	Swat	PIL-36	3/18/2018	30.00%	In Progress
70	GPS Dardyal	Swat	PIL-36	26-3-2018	18.00%	Work Stopped
71	GPS Matiltan	Swat	PIL-36	22-03-2019	35.00%	In Progress
72	GPS Pir Patey Qalagai	Swat	PIL-36	26-3-2018	30.00%	In Progress
73	GPS Qala Qalagai	Swat	PIL-36	26-3-2018	0.75%	Work Stopped
74	GPS Usho	Swat	PIL-36	8/4/2019	44.63%	In Progress
75	GGHS No.1 Mingora	Swat	PIL-36	11-10-19 (Package -3)	30.31%	In Progress
76	GGPS Naway Kalay	Swat	PIL-36		25.00%	In Progress
77	GPS Gulzada Kaley	Malakand	PIL-36	10/11/2019	32.00%	In Progress
78	GGCMHS Thana	Malakand	PIL-36	10/11/2019	27.00%	In Progress
79	GHS Jan Batti	Dir Upper	PIL-36	8/11/2016	100.00%	Completed
80	GGPS Saddar Ghari	Charsadda	PIL-36	3/8/2018	40.95%	In Progress
81	GPS No. 1 Katozai	Charsadda	PIL-36	3/8/2018	72.55%	In Progress
82	GHS Khwishgi Bala	Nowshehra	PIL-36	3/8/2018	60.00%	In Progress
83	GHSS No.1 Nowshehra Kalan	Nowshehra	PIL-36	3/8/2018	45.00%	In Progress
84	GHS Masho Khail	Peshawar	PIL-36	19/3/2019	10.00%	In Progress
85	GPS Karam Khel Mushtarzai	Peshawar	PIL-36	3/8/2018	10.00%	Work Stopped
86	GGPS Panam Dari	Peshawar	PIL-36	6/11/2018	35.00%	In Progress
87	GHS Matani	Peshawar	PIL-36	3/8/2018	38.00%	In Progress
88	GPS No. 2 Maira Balar Zai	Peshawar	PIL-36	6/11/2018	0.77%	In Progress
89	GPS Yari Koroona	Peshawar	PIL-36	3/8/2018	55.00%	In Progress
90	DWSS Kingargalai	Buner	PIL-38	29-01-2019	93.00%	Work stopped
91	DWSS Bampokha	Buner	PIL-38	4/2/2019	0.00%	Work stopped
92	DWSS Jowar No.2	Buner	PIL-38	30-01-2019	80.10%	In Progress
93	DWSS Spina Khawra	Buner	PIL-38	29-01-2019	95.10%	In Progress
94	DWSS Dewana Baba No.1	Buner	PIL-38	14-02-2019	93.10%	In Progress
95	DWSS Koga	Buner	PIL-38	1/30/2019	42.00%	Work stopped
96	DWSS Dhandar	Buner	PIL-38	30-01-2019	93.10%	In Progress
97	DWSS Charkot	Buner	PIL-38	14-02-2019	13.50%	Work stopped
98	DWSS Ghurghushto	Buner	PIL-38	29-01-2019	75.10%	In Progress
99	On Line Monitoring System	Swat	PIL-38		90%	Work Stopped
100	Bara Durashkhela Qalla Road (1 Km)	Swat	PIL-39	06-05-2019		Work order issued. Work not yet started.
101	Gujar Banr Awi Shah Road (1.75 Km)	Swat	PIL-39	06-05-2019	50.00%	Work Stopped
102	Bazkhela to Gal Shah Road (1.15 Km).	Swat	PIL-39	06-05-2019	30.00%	In Progress
103	Sakhra Dispensary to Amloko Road (0.9 Km).	Swat	PIL-39	06-05-2019		Work order issued but still no submission of milestone for certifications
104	Bar Gujar Banr Road (2 Km)	Swat	PIL-39		10.00%	In Progress
105	Shokh Dara Deran Patay Road (1.3 Km)	Swat	PIL-39	30-04-2019		Work order issued but still no submission of milestone for certifications
106	Flood Protection Works at Fizagut, Mingora Bypass	Swat	PIL-39	30-04-2019	52.31%	In Progress

Architect-Engineer Independent Quality Assurance and Milestone Certification Services for USAID's Federally Administered Tribal Areas Infrastructure and Khyber Pakhtunkhwa Reconstruction Programs (A-E FIP KPRP)
FATA Infrastructure Program (FIP) - List of Projects

As of July 31, 2020

S.No	Project Description	District	PIL/FARA	Date of Work Order	Status	Progress (%age)
Orakzai Package-1						
1	GGPS Ramadan (Pacha Panra)	Orakzai	PIL-39	18-Feb-19	In progress	2.00%
2	GGPS Talay Ali Khel	Orakzai	PIL-39	18-Feb-19	Work stopped	-
3	GPS Malang Garhi	Orakzai	PIL-39	18-Feb-19	In progress	5.00%
4	GPS Garhi Mishti	Orakzai	PIL-39	18-Feb-19	Work stopped	100.00%
5	GGPS Chota Bezot	Orakzai	PIL-39	18-Feb-19	Work stopped	0.37%
6	GPS Kasim Khel	Orakzai	PIL-39	18-Feb-19	Work stopped	1.90%
7	GMS Khadazai Stara Kada	Orakzai	PIL-39	18-Feb-19	Work stopped	0.55%
8	GPS Inzerki	Orakzai	PIL-39	18-Feb-19	In progress	65.00%
9	GPS Kandi Mishti	Orakzai	PIL-39	18-Feb-19	Work stopped	80.00%
10	GGMS Tooti Bagh	Orakzai	PIL-39	18-Feb-19	Work stopped	60%
11	GPS Dray Sotay	Orakzai	PIL-39	18-Feb-19	Work stopped	0.62%
Orakzai Package-2						
12	GHS Swaro kot	Orakzai	PIL-43	-	In Tendering stage	65%
13	GGHS Spen Beghi	Orakzai	PIL-43	-	In Tendering stage	-
14	GHS Goeen	Orakzai	PIL-43	-	In Tendering stage	75%
15	GGHS Togha Sam	Orakzai	PIL-43	-	In Tendering stage	75%
16	GGPS Sarki Khel	Orakzai	PIL-43	-	In Tendering stage	-
17	GPS Spen Beghi	Orakzai	PIL-43	-	In Tendering stage	-
18	GPS Goeen Bala	Orakzai	PIL-43	-	In Tendering stage	-
19	GPS Kool	Orakzai	PIL-43	-	In Tendering stage	-
Orakzai Package-3						
20	GPS Kasha	Orakzai	PIL-43	-	In Tendering stage	-
21	GGPS Zanka khel	Orakzai	PIL-43	-	In Tendering stage	-
22	GPSS Dago Takhtak	Orakzai	PIL-43	-	In Tendering stage	-
23	GGPS Gori Kach	Orakzai	PIL-43	-	In Tendering stage	-
24	GGMS Saifi Dara	Orakzai	PIL-43	-	In Tendering stage	-
25	GHS Awi Mela	Orakzai	PIL-43	-	In Tendering stage	-
Orakzai Package-4						
26	GPS Dara Sultan Nawasi	Orakzai	Not yet signed	-	In Tendering stage	-
27	GPS Kool	Orakzai	Not yet signed	-	In Tendering stage	-
28	GPS Umer Sheikhan	Orakzai	Not yet signed	-	In Tendering stage	-
29	GPS Torri Mela	Orakzai	Not yet signed	-	In Tendering stage	-
Militancy Damaged Schools						
Kurram P-1						
30	GPS Tari Tang	Kurram	PIL-39	22-Nov-19	Not yet started	-
31	GPS Star Jumat	Kurram	PIL-39	22-Nov-19	Not yet started	-
32	GPS Dargai No 3	Kurram	PIL-39	-	In tendering stage	-
33	GPS Dargai No 2	Kurram	PIL-39	-	In tendering stage	-
34	GPS Shekhana	Kurram	PIL-39	22-Nov-19	Not yet started	-
35	GPS Tatang	Kurram	PIL-39	22-Nov-19	Not yet started	-
36	GPS Kuram	Kurram	PIL-39	22-Nov-19	Not yet started	-
37	GPS Takhtak	Kurram	PIL-39	-	In tendering stage	-
38	GPS Mandan	Kurram	PIL-39	22-Nov-19	Not yet started	-
39	GGPS Darkali	Kurram	PIL-39	-	In tendering stage	-
40	GGPS Kot Nakai	Kurram	PIL-39	-	In tendering stage	-
41	GPS Margha Dara	Kurram	PIL-39	-	In tendering stage	-
42	GPS Arghonja	Kurram	PIL-39	-	In tendering stage	95%
43	GPS Nikaziarat	Kurram	PIL-39	22-Nov-19	Not yet started	100%
44	GPS Samandar Kalai	Kurram	PIL-39	22-Nov-19	Not yet started	-
45	GHS Badama (Primary section)	Kurram	PIL-39	2-Sep-19	In progress	75.00%
46	GMS Gawaki	Kurram	PIL-39	-	In tendering stage	-
Kurram P-2						
47	GPS Baza	Kurram	PIL-43	22-Nov-19	Not yet started	-
48	GGPS Hassan Zai	Kurram	PIL-43	22-Nov-19	In progress	30.00%
49	GPS Durrani	Kurram	PIL-43	22-Nov-19	Not yet started	-
50	GGPS Maro khel	Kurram	PIL-43	22-Nov-19	Not yet started	20%
51	GGPS Khurmana	Kurram	PIL-43	22-Nov-19	Not yet started	-
MD Schools FR Kohat						
52	GPS Shahi Khel	FR Kohat	PIL-36	-	In tendering stage	-
53	GPS Feroz Kalay	FR Kohat	PIL-36	30-Sep-19	In progress	78.00%
54	GPS Sawar Khel	FR Kohat	PIL-36	-	In tendering stage	55.00%
55	GGPS Zoor Kalay	FR Kohat	PIL-36	4-Dec-19	In progress	5.00%
56	GMS Kohi Wal	FR Kohat	PIL-36	5-Dec-19	In progress	37.00%

Architect-Engineer Independent Quality Assurance and Milestone Certification Services for USAID's Federally Administered Tribal Areas Infrastructure and Khyber Pakhtunkhwa Reconstruction Programs (A-E FIP KPRP)
FATA Infrastructure Program (FIP) - List of Projects

As of July 31, 2020

S.No	Project Description	District	PIL/FARA	Date of Work Order	Status	Progress (%age)
57	GGMS Noor Ali Khel	FR Kohat	PIL-36	27-Nov-19	Not yet started	35.00%
58	GMS Sara Mela Bosti Khel	FR Kohat	PIL-36	5-Dec-19	Not yet started	
59	GGMS Jammu Shahi Khel	FR Kohat	PIL-36	-	In tendering stage	18.00%
60	GGMS Bilal Kalay	FR Kohat	PIL-36	5-Dec-19	In progress	15.00%
61	GGMS Surak Toor Chapper	FR Kohat	PIL-36	4-Oct-19	Not yet started	23.00%
62	GGMS Jani Khel	FR Kohat	PIL-36	5-Dec-19	In progress	30.00%
63	GGMS Suni Khel	FR Kohat	PIL-36	4-Dec-19	In progress	30.00%
	MD Schools FR Peshawar 06					35%
64	GGPS Jannat Khan	FR Peshawar	PIL-36	2-Dec-19	Not yet started	45.00%
65	GPS Bora-2	FR Peshawar	PIL-36	2-Dec-19	In progress	55.00%
66	GHS Bora	FR Peshawar	PIL-36	30-Sep-19	In progress	45.00%
67	GHS Musa Dara	FR Peshawar	PIL-36	-	In tendering stage	-
68	GGHSS Samand Khan	FR Peshawar	PIL-36	7-Jan-20	Not yet started	-
69	GGHS Malik Noman Kalay	FR Peshawar	PIL-36	4-Oct-19	In progress	0.50%
	Govt. Degree College Dogar Kurram					
70	Main Building	Dogar Kurram	PIL-44	-	In tendering stage	88%
71	GHS Pashtoon Ghari	Dogar Kurram	PIL-44	-	In tendering stage	-
72	Type - IV Quarter	Dogar Kurram	PIL-44	-	In tendering stage	-
73	Type - III Quarter	Dogar Kurram	PIL-44	-	In tendering stage	-
74	GHSS Akbarpura	Dogar Kurram	PIL-44	-	In tendering stage	-
75	Guard Room	Dogar Kurram	PIL-44	-	In tendering stage	-
76	Boundary wall	Dogar Kurram	PIL-44	-	In tendering stage	-
77	Pavements, Lawns & Flag Post	Dogar Kurram	PIL-44	-	In tendering stage	-
78	Internal Road	Dogar Kurram	PIL-44	-	In tendering stage	-
79	External Water Supply	Dogar Kurram	PIL-44	-	In tendering stage	-
80	External Sewerage system	Dogar Kurram	PIL-44	-	In tendering stage	-
81	Drainage work	Dogar Kurram	PIL-44	-	In tendering stage	-
82	Retaining wall	Dogar Kurram	PIL-44	-	In tendering stage	-
83	Over head Tank	Dogar Kurram	PIL-44	-	In tendering stage	-
84	Borewell	Dogar Kurram	PIL-44	-	In tendering stage	-
85	Confirmatory Boring including SPT's, samples, lab test, bore-hole logs, report : in Gravelly Soil	Dogar Kurram	PIL-44	-	In tendering stage	-
86	Project Sign board	Dogar Kurram	PIL-44	-	In tendering stage	20%
87	Shifting of Electric pole - (02.Nos)	Dogar Kurram	PIL-44	-	In tendering stage	35%
	Govt. Technical Institute Ghiljo Orakzai					
88	GTI MAIN BUILDING	Ghiljo Orakzai	PIL-45		In tendering stage	30%
89	BOYS HOSTEL	Ghiljo Orakzai	PIL-45		In tendering stage	65%
90	Type-IV Quarter (2 Nos)	Ghiljo Orakzai	PIL-45		In tendering stage	10%
91	Type - III Quarter	Ghiljo Orakzai	PIL-45		In tendering stage	40%
92	Type - V Quarter (3 Nos)	Ghiljo Orakzai	PIL-45		In tendering stage	30%
93	Cafateria	Ghiljo Orakzai	PIL-45		In tendering stage	30%
94	Guard Room	Ghiljo Orakzai	PIL-45		In tendering stage	
95	Lavatory block	Ghiljo Orakzai	PIL-45		In tendering stage	30%
96	Boundary wall	Ghiljo Orakzai	PIL-45		In tendering stage	18%
97	Pavements, Lawns & Flag Post	Ghiljo Orakzai	PIL-45		In tendering stage	35%
98	External Water Supply	Ghiljo Orakzai	PIL-45		In tendering stage	30%
99	External Sewerage system	Ghiljo Orakzai	PIL-45		In tendering stage	
100	Drainage work	Ghiljo Orakzai	PIL-45		In tendering stage	
101	Repair work in Existing Over Head Water Tank	Ghiljo Orakzai	PIL-45		In tendering stage	
102	Borewell	Ghiljo Orakzai	PIL-45		In tendering stage	25%
103	Confirmatory Boring including SPT's, samples, lab test, bore-hole logs, report : in Gravelly Soil	Ghiljo Orakzai	PIL-45		In tendering stage	32%
104	Project Sign board	Ghiljo Orakzai	PIL-45		In tendering stage	27%
105	SURFACE TANK	Ghiljo Orakzai	PIL-45		In tendering stage	100%
106	Transformer	Ghiljo Orakzai	PIL-45		In tendering stage	
107	Security Light	Ghiljo Orakzai	PIL-45		In tendering stage	
	Civil Hospital Muzaffarkot Kurram					60%
108	Main Hospital Building	Kurram	PIL-45		In progress	45%
109	GHS Masho Khail	Kurram	PIL-45		Not yet started	
110	Doctor Hostel (2 Nos)	Kurram	PIL-45		Not yet started	
111	GGPS Panam Dari	Kurram	PIL-45		Not yet started	
112	Type - V Quarter (4 Nos)	Kurram	PIL-45		Not yet started	
113	Type - IV Quarter (7 Nos)	Kurram	PIL-45		Not yet started	
114	GPS Yari Koroona	Kurram	PIL-45		Not yet started	
115	Guard Room	Kurram	PIL-45		Not yet started	
116	Electrical Room	Kurram	PIL-45		Not yet started	
117	Boundary wall	Kurram	PIL-45		Not yet started	
118	Pavements, Lawns & Flag Post	Kurram	PIL-45		Not yet started	

Architect-Engineer Independent Quality Assurance and Milestone Certification Services for USAID's Federally Administered Tribal Areas Infrastructure and Khyber Pakhtunkhwa Reconstruction Programs (A-E FIP KPRP)
FATA Infrastructure Program (FIP) - List of Projects

As of July 31, 2020

S.No	Project Description	District	PIL/FARA	Date of Work Order	Status	Progress (%)
119	Road	Kurram	PIL-45		Not yet started	
120	External Water Supply	Kurram	PIL-45		Not yet started	
121	External Sewerage system	Kurram	PIL-45		Not yet started	
122	Drainage work	Kurram	PIL-45		Not yet started	
123	Over head Tank	Kurram	PIL-45		Not yet started	
124	Borewell	Kurram	PIL-45		Not yet started	
125	Confirmatory Boring including SPT's, samples, lab test, bore-hole logs, report : in Gravelly Soil	Kurram	PIL-45		Not yet started	
126	Project Sign board	Kurram	PIL-45		Not yet started	50%
127	Surface Tank	Kurram	PIL-45		Not yet started	30%
128	Solar System	Kurram	PIL-45		Not yet started	
129	Security Lights	Kurram	PIL-45		Not yet started	10%
130	Transformer	Kurram	PIL-45		Not yet started	
131	Diesel Generator100kVA+ATS	Kurram	PIL-45		Not yet started	
132	Fire Alarm System	Kurram	PIL-45		Not yet started	
	Jamrud Bypass road Khyber 7.780 Km					
133	P-I (0+00 ~ 4+042) = 4.042 km	Khyber	PIL-34	28-Mar-19	Not yet started	
134	P-II (4+042 ~ 4+219) = 0.177 km (Bridge)	Khyber	PIL-34	28-Mar-19	Work stoped	
135	P-III (4+219 ~ 7+780) 3.561 km	Khyber	PIL-34	28-Mar-19	Work stoped	
	Bara to Shin Kamar to Mastak (RD 0+000 ~ 42+550) = 42.550 km Khyber					
	Bara to Shin Kamar Phase-1 (0+000 ~ 25+000) = 25 km					
136	(Package- 1) = 8 Km	Khyber	PIL-44	3-Sep-19	In progress	1.70%
137	(Package- 2) = 8 Km	Khyber	PIL-44	9-Sep-19	In progress	1.00%
138	(Package- 3) = 9 Km	Khyber	PIL-44	25-Sep-19	In progress	1.80%
	Shin Kamar to Mastak Phase-2 (25+000 ~ 42+550) = 17.550 km					
139	(Package- 1) = 8.50	Khyber	PIL-44	3-Sep-19	In progress	0.00%
140	(Package- 2) = 9.050	Khyber	PIL-44	9-Sep-19	In progress	0.00%
	Loesam Nawapass (RD 0+000 ~ 30+750) = 30.750 km Bajaur					
141	P-I (0+000 ~ 10+000) = 10 km	Bajaur	PIL-35	7-Jan-19	In progress	27.13%
142	P-II (11+000 ~ 20+000) = 10 km	Bajaur	PIL-35	7-Jan-19	In progress	23.31%
143	P-III (20+000 ~ 30+750) = 10.75 km	Bajaur	PIL-35	7-Jan-19	In progress	18.27%
	Asil Targhaw road (RD 0+000 ~ 20+575) = 20.575 km Bajaur					
144	P-I (0+000 ~ 10+225) = 10.225 km	Bajaur	PIL-40	20-Jan-19	In progress	30.07%
145	P-II (10+225 ~ 20+575) 10.350 km	Bajaur	PIL-40	20-Jan-19	In progress	18.73%
	Murghan to Nika ziarat road (RD 0+000 ~ 23+813) = 23.813 km Kurram					
146	P-I (0+000 ~ 11+907) = 11.907 km	Kurram	PIL-38	2-Nov-18	Work stoped	17.83%
147	P-II (11+907 ~ 23+813) 11.906 km	Kurram	PIL-38	2-Nov-18	Work stoped	17.75%
	Ghiljo to Dabori road (RD 0+000 ~ 18+000) = 18 km Orakzai					
148	P-I (0+000 ~ 10+000) = 10 km	Orakzai	PIL-45		Work stoped	
149	P-II (10+000 ~ 18+000) = 8 km	Orakzai	PIL-45		Work stoped	
	132kV Grid Station, Khar Bajaur					
150	132kV Grid Station, Khar	Khar Bajaur	PIL-26	05-01-2015, 01-10-2015, 05-10-2015,	Work stoped	94.00%
	132kV Transmission Line, Khar Bajaur					
151	132kV Transmission Line, Khar	Khar Bajaur	PIL-33	18-Jul-17	In Progress	77.80%
	132kV Grid Station, Jandola					
152	132kV Grid Station, Jandola	Jandola	PIL-41		In progress	38.00%
	132 KV TL Pezu - Tank - Jandola					
153	132 KV TL Pezu - Tank - Jandola	Jandola	PIL-46		In tendering stage	
	Rehab 11 KV Damaged Distrib System Phase-II (SWA)					
154	Rehab 11 KV Damaged Distrib System Phase-II (SWA)		PIL-37		Work stoped	28.00%
	Drinking Water Supply Schemes (Civil)					
155	DWSS Lara Dagai, Salarzai	Bajaur Non operational	PIL-42	21/Dec/2018	Not yet started	-
156	DWSS Shagai, Salarzai	Bajaur Non operational	PIL-42	21/Dec/2018	Work stoped	77.84%
157	DWSS Shago, Khar Astana Gul Killi	Bajaur Non operational	PIL-42	21/Dec/2018	Work stoped	45.54%
158	DWSS Dolasmanai, Salarzai	Bajaur Non operational	PIL-42	21/Dec/2018	Work stoped	76.10%

Architect-Engineer Independent Quality Assurance and Milestone Certification Services for USAID's Federally Administered Tribal Areas Infrastructure and Khyber Pakhtunkhwa Reconstruction Programs (A-E FIP KPRP)
FATA Infrastructure Program (FIP) - List of Projects

As of July 31, 2020

S.No	Project Description	District	PIL/FARA	Date of Work Order	Status	Progress (%age)
159	DWSS Loe Sum, Khar	Bajaur Non operational	PIL-42	21/Dec/2018	Work stopped	0.52%
160	DWSS Zoor Bandar, Khar	Bajaur operational	PIL-42	21/Dec/2018	Work stopped	0.60%
161	DWSS Bai China, Khar	Bajaur operational	PIL-42	21/Dec/2018	In progress	44.33%
162	Nawagai B/Station-1	Bajaur operational	PIL-42	21/Dec/2018	Not yet started	-
163	DWSS Loe Jowar Khar	Bajaur operational	PIL-42	21/Dec/2018	Work stopped	78.42%
164	DWSS Lagharai, Mamund	Bajaur operational	PIL-42	21/Dec/2018	Work stopped	69.29%
165	DWSS Yousaf Abad, Khar	Bajaur operational	PIL-42	21/Dec/2018	Not yet started	0.00%
166	DWSS Kamar Killi, Mamund	Bajaur operational	PIL-42	21/Dec/2018	Not yet started	0.00%
167	DWSS Tangai Tube Well No.1, Charmang	Bajaur operational	PIL-42	21/Dec/2018	Work stopped	81.14%
168	DWSS Jowar Qilla, Salarzi Zone-B	Bajaur operational	PIL-42	21/Dec/2018	Not yet started	0.00%
169	DWSS Loe Ghunai, Khar	Bajaur operational	PIL-42	21/Dec/2018	In progress	0.87%
170	DWSS Maram Ghundai Sara Mena, Khar	Bajaur operational	PIL-42	21/Dec/2018	Work stopped	88.00%
171	DWSS Dak Qilla Atizi, Khar	Bajaur operational	PIL-42	21/Dec/2018	Work stopped	10.00%
	Drinking Water Supply Schemes (Solar)					
172	DWSS Lara Dagai, Salarzai	Bajaur Non operational	PIL-42	-	Not yet started	-
173	DWSS Shago, Khar Astana Gul Killi	Bajaur Non operational	PIL-42	25-Apr-19	In progress	85.00%
174	DWSS Dolasmanai, Salarzai	Bajaur Non operational	PIL-42		In progress	85.00%
175	DWSS Loe Sum, Khar	Bajaur operational	PIL-42	25-Apr-19	In progress	50.00%
176	DWSS Zoor Bandar, Khar	Bajaur operational	PIL-42	25-Apr-19	Work stopped	-
177	DWSS Bai China Khar	Bajaur operational	PIL-42	-	Not yet started	-
178	Nawagai B/Station-1	Bajaur operational	PIL-42	-	Not yet started	-
179	DWSS Loe Jowar Khar	Bajaur operational	PIL-42	-	In progress	85.00%
180	DWSS Kamar Killi, Mamund	Bajaur operational	PIL-42	25-Apr-19	Work stopped	25.00%
181	DWSS Jowar Qilla, Salarzi Zone-B	Bajaur operational	PIL-42	-	in progress	55.00%
182	DWSS Loe Ghunai, Khar	Bajaur operational	PIL-42	-	Work stopped	25.00%
183	DWSS Maram Ghundai Sara Mena, Khar	Bajaur operational	PIL-42	25-Apr-19	In progress	90.00%
184	DWSS Dak Qilla Atizi, Khar	Bajaur operational	PIL-42	-	In progress	85.00%
	Drinking Water Supply Schemes (Civil)					
185	DWSS-Faridi Hassan Khel	FR Peshawar	PIL-42	5-Nov-2018	In progress	89.00%
186	DWSS Sama Bada Bera T/W-1	FR Peshawar	PIL-42	2-Nov-2018	In progress	89.84%
187	DWSS Hassan Khel-2	FR Peshawar	PIL-42	5-Nov-2018	In progress	84.65%
	Drinking Water Supply Schemes (Solar)					
188	DWSS-Faridi Hassan Khel	FR Peshawar	PIL-42	16-May-19	In progress	90%
189	DWSS Sama Bada Bera T/W-1	FR Peshawar	PIL-42	16-May-19	In progress	25%
190	DWSS Hassan Khel-2	FR Peshawar	PIL-42	16-May-19	In progress	90%
	Drinking Water Supply Schemes (Civil)					
191	DWSS Akhurwal	FR Kohat	PIL-42	5-Nov-2018	In progress	69.00%
	Drinking Water Supply Schemes (Solar)					
192	DWSS Akhurwal	FR Kohat	PIL-42	16-May-19	in progress	25%
	Drinking Water Supply Schemes (Civil)					
193	DWSS Shahkass-2 Jamrud	Khyber	PIL-42	24-Jun-2019	In progress	35.30%
194	DWSS Shahkass-3 Jamrud	Khyber	PIL-42	24-Jun-2019	In progress	36.58%
195	DWSS Shahkass-4 Jamrud	Khyber	PIL-42	24-Jun-2019	In progress	34.98%
196	DWSS Shahkass-5 Jamrud	Khyber	PIL-42	19-Jun-2019	Work stopped	1.00%
197	DWSS Ghundi -1 Jamrud	Khyber	PIL-42	19-Jun-2019	In progress	28.60%
198	DWSS Ghundi-2 Jamrud	Khyber	PIL-42	24-Jun-2019	Work stopped	0.67%
199	DWSS Ghundi- 5 Jamrud	Khyber	PIL-42	24-Jun-2019	Work stopped	6.00%
200	DWSS Ghariza- 1 Jamrud	Khyber	PIL-42	19-Jun-2019	Work stopped	4.00%
201	DWSS Surkamar-1 Jamrud	Khyber	PIL-42	24-Jun-2019	In progress	12.48%
202	DWSS Godar-3 Jamrud	Khyber	PIL-42		In progress	12.24%
203	DWSS Wazir Dhand-2 Jamrud	Khyber	PIL-42	19-Jun-2019	Not yet started	-
204	DWSS Ali Masjid Area Jamrud	Khyber	PIL-42	24-Jun-2019	In progress	19.42%
	Drinking Water Supply Schemes (Solar)					
205	DWSS Shahkass-2 Jamrud	Khyber	PIL-42	16-May-2019	Not yet started	-
206	DWSS Shahkass-3 Jamrud	Khyber	PIL-42	16-May-2019	Not yet started	-
207	DWSS Shahkass-4 Jamrud	Khyber	PIL-42	16-May-2019	in progress	25%
208	DWSS Shahkass-5 Jamrud	Khyber	PIL-42	16-May-2019	Not yet started	-
209	DWSS Ghundi-1 Jamrud	Khyber	PIL-42	16-May-2019	Not yet started	-
210	DWSS Ghundi-2 Jamrud	Khyber	PIL-42	16-May-2019	Not yet started	-
211	DWSS Ghundi-5 Jamrud	Khyber	PIL-42	16-May-2019	Not yet started	-
212	DWSS Ghariza -1 Jamrud	Khyber	PIL-42	16-May-2019	Not yet started	-
213	DWSS Surkamar-1 Jamrud	Khyber	PIL-42	16-May-2019	in progress	25%
214	DWSS Godar-3 Jamrud	Khyber	PIL-42	16-May-2019	in progress	25%
215	DWSS Wazir Dhand-2 Jamrud	Khyber	PIL-42	16-May-2019	Not yet started	-
216	DWSS Ali Masjid Area Jamrud	Khyber	PIL-42	16-May-2019	Not yet started	-
	Drinking Water Supply Schemes (Civil)					

Architect-Engineer Independent Quality Assurance and Milestone Certification Services for USAID's Federally Administered Tribal Areas Infrastructure and Khyber Pakhtunkhwa Reconstruction Programs (A-E FIP KPRP)
FATA Infrastructure Program (FIP) - List of Projects

As of July 31, 2020

S.No	Project Description	District	PIL/FARA	Date of Work Order	Status	Progress (%age)
217	DWSS Hamza Khel Halimzai (Hameesh)	Mohmand	PIL-42	16-Nov-2018	Not yet started	-
218	DWSS Khuram Cheena Halimzai	Mohmand	PIL-42	16-Nov-2018	Work stopped	1.00%
219	DWSS Sultan Khel Nasapay	Mohmand	PIL-42	16-Nov-2018	Work stopped	27.00%
220	DWSS Alam Baig Kamaly	Mohmand	PIL-42	16-Nov-2018	Work stopped	29.63%
221	DWSS Shah Baig Yasin Kore	Mohmand	PIL-42	16-Nov-2018	Not yet started	-
222	DWSS Shati Kor Halimzai	Mohmand	PIL-42	16-Nov-2018	Work stopped	58.41%
223	DWSS Sultan Khel Halimzai	Mohmand	PIL-42	16-Nov-2018	Work stopped	38.00%
224	DWSS Ato Khel Halimzai	Mohmand	PIL-42	16-Nov-2018	In progress	7.17%
225	DWSS Mohra Mettai Baizai	Mohmand	PIL-42	16-Nov-2018	In progress	0.94%
226	DWSS Dag Killi Baizal	Mohmand	PIL-42	16-Nov-2018	Not yet started	0.00%
227	DWSS Mazi Kore Baizai	Mohmand	PIL-42	16-Nov-2018	Work stopped	0.47%
228	DWSS Abdul Khel Zaman Kore Baizai	Mohmand	PIL-42	16-Nov-2018	Not yet started	-
229	DWSS Faqir Abad Baizai	Mohmand	PIL-42	16-Nov-2018	Work stopped	0.67%
230	DWSS Jabbar Jaour Baizai	Mohmand	PIL-42	16-Nov-2018	Not yet started	-
231	DWSS Ghanum Shah Baizai (Malik Zareen)	Mohmand	PIL-42	16-Nov-2018	in progress	38.51%
232	DWSS Koda Khel Baizai	Mohmand	PIL-42	16-Nov-2018	In progress	45.00%
233	DWSS Ghair Dhand Baizai	Mohmand	PIL-42	16-Nov-2018	Not yet started	-
234	DWSS Ghanam Shah (Malik Bashir)	Mohmand	PIL-42	16-Nov-2018	In progress	42.82%
Drinking Water Supply Schemes (Solar)						
235	DWSS Hamza Khel Halimzai (Hameesh)	Mohmand	PIL-42	13-Feb-19	Not yet started	-
236	DWSS Khuram cheena Halimzai	Mohmand	PIL-42	22-Feb-19	Not yet started	-
237	DWSS Sultan Khel Nasapay	Mohmand	PIL-42	-	In tendering stage	-
238	DWSS Alam Baig Kamaly	Mohmand	PIL-42	25-Apr-19	in progress	25%
239	DWSS Shah Baig Yasin Kore	Mohmand	PIL-42	25-Apr-19	Not yet started	-
240	DWSS Shati kor Halimzai	Mohmand	PIL-42	25-Apr-19	in progress	85%
241	DWSS Sultan khel Halimzai	Mohmand	PIL-42	25-Apr-19	in progress	55%
242	DWSS Ato khel Halimzai	Mohmand	PIL-42	25-Jun-19	Not yet started	-
243	DWSS Mohra Mettai Baizai	Mohmand	PIL-42	22-Feb-19	Not yet started	-
244	DWSS Dag Killi Baizal	Mohmand	PIL-42	-	In tendering stage	-
245	DWSS Mazi Kore Baizai	Mohmand	PIL-42	22-Feb-19	Not yet started	-
246	DWSS Abdul Khel Zaman Kore Baizai	Mohmand	PIL-42	-	Not yet started	-
247	DWSS Faqir Abad Baizai	Mohmand	PIL-42	22-Feb-19	Not yet started	-
248	DWSS Jabbar Jaour Baizai	Mohmand	PIL-42	-	In tendering stage	-
249	DWSS Ghanum Shah Baizai	Mohmand	PIL-42	-	In tendering stage	-
250	DWSS Koda Khel Baizai	Mohmand	PIL-42	-	In tendering stage	-
251	DWSS Ghair Dhand Baizai	Mohmand	PIL-42	-	In tendering stage	-
252	DWSS Ghanam Shah	Mohmand	PIL-42	-	In tendering stage	-
Irrigation Water Supply Schemes (Civil)						
253	Sifat Khan /1/4503 (Gadia Khel)	FR Kohat	PIL-44	17-Jul-2019	Not yet started	-
254	Arshad Iqbal /4--4506 (Bashri Kali)	FR Kohat	PIL-44	17-Jul-2019	Not yet started	-
255	Siraj Khan /4511 (Shamal Khel)	FR Kohat	PIL-44	17-Jul-2019	Work stopped	1.01%
256	Malik Shah Jan /4513 (Akhur Wall)	FR Kohat	PIL-44	17-Jul-2019	In progress	99.50%
Irrigation Water Supply Schemes (Solar)						
257	1/4503 (Gadia Khel)	FR Kohat	PIL-44	13-Nov-19	Not yet started	-
258	4--4506 (Bashri Kali)	FR Kohat	PIL-44	13-Nov-19	Not yet started	-
259	4511(Shamal Khel)	FR Kohat	PIL-44	13-Nov-19	Not yet started	-
260	4513 (Akhur Wall)	FR Kohat	PIL-44	13-Nov-19	In progress	25%
Irrigation Water Supply Schemes (Civil)						
261	TW # 2 (Shamat Khel)	FR Peshawar	PIL-44	-	In progress	72.44%
262	Khewa Kheil	FR Peshawar	PIL-44	-	In progress	93.00%
Irrigation Water Supply Schemes (Solar)						
263	TW # 2 (Shamt Khel)	FR Peshawar	PIL-44	13-Nov-19	In progress	25%
264	Khewa Kheil	FR Peshawar	PIL-44	13-Nov-19	In progress	25%
Irrigation Water Supply Schemes (Civil)						
265	Tang Khata	Bajaur	PIL-44	13/Nov/2018	Not yet started.	0.00%
266	Khair Abad	Bajaur	PIL-44	13/Nov/2018	Not yet started.	0.00%
267	Aman Kot	Bajaur	PIL-44	13/Nov/2018	Not yet started.	-
268	Shamshak (Sadiq abad)	Bajaur	PIL-44	13/Nov/2018	Work stopped	0.80%
269	Ghali Shah	Bajaur	PIL-44	13/Nov/2018	In progress	23.12%
270	Dherai Tangkhata	Bajaur	PIL-44	13/Nov/2018	Not yet started.	0.00%
271	Mulano Killi	Bajaur	PIL-44	13/Nov/2018	Work stopped	0.32%
272	Narrai Shah	Bajaur	PIL-44	13/Nov/2018	Not yet started.	0.00%
273	Shukrata (Qazafi)	Bajaur	PIL-44	13/Nov/2018	Work stopped	84.73%
274	Dag Loe Sum	Bajaur	PIL-44	13/Nov/2018	Work stopped	1.00%
275	Bar Kamer	Bajaur	PIL-44	13/Nov/2018	Not yet started.	-
276	Kamer Jan	Bajaur	PIL-44	13/Nov/2018	Work stopped	1.00%
277	Sewai	Bajaur	PIL-44	13/Nov/2018	Dropped/Replaced	-
278	Umarai-1	Bajaur	PIL-44	13/Nov/2018	Not yet started.	0.00%
279	JangZai	Bajaur	PIL-44	13/Nov/2018	Dropped/Replaced	-
280	Dando	Bajaur	PIL-44	13/Nov/2018	Not yet started.	0.00%

Architect-Engineer Independent Quality Assurance and Milestone Certification Services for USAID's Federally Administered Tribal Areas Infrastructure and Khyber Pakhtunkhwa Reconstruction Programs (A-E FIP KPRP)
FATA Infrastructure Program (FIP) - List of Projects

As of July 31, 2020

S.No	Project Description	District	PIL/FARA	Date of Work Order	Status	Progress (%age)
281	Loe Sam	Bajaur	PIL-44	13/Nov/2018	Not yet started.	0.00%
282	Shago Chianagai	Bajaur	PIL-44	13/Nov/2018	Not yet started.	0.00%
283	Erab	Bajaur	PIL-44	13/Nov/2018	Not yet started.	-
284	Chingazo	Bajaur	PIL-44	13/Nov/2018	In progress	38.40%
285	Kharai Kamer	Bajaur	PIL-44	13/Nov/2018	Not yet started.	0.00%
286	Tangi	Bajaur	PIL-44	13/Nov/2018	Work stopped	1.00%
287	Girai-1	Bajaur	PIL-44	13/Nov/2018	Work stopped	25.00%
288	Pacha Killi	Bajaur	PIL-44	13/Nov/2018	Work stopped	0.80%
289	Muslim Bagh	Bajaur	PIL-44	13/Nov/2018	Dropped/Replaced	-
290	Threma Thrash	Bajaur	PIL-44	13/Nov/2018	Work stopped	0.57%
291	Gafoor Shah	Bajaur	PIL-44	13/Nov/2018	Work stopped	0.57%
292	Bar Khalozai	Bajaur	PIL-44	13/Nov/2018	Not yet started.	-
293	Bar Khar Kano	Bajaur	PIL-44	13/Nov/2018	Work stopped	0.57%
294	Balolai	Bajaur	PIL-44	13/Nov/2018	Work stopped	0.55%
295	Dabdaboo	Bajaur	PIL-44	13/Nov/2018	Work stopped	0.80%
296	Toot Shah	Bajaur	PIL-44	13/Nov/2018	Work stopped	49.33%
297	Kausar	Bajaur	PIL-44	13/Nov/2018	Not yet started.	-
298	Jour Qilla	Bajaur	PIL-44	13/Nov/2018	Work stopped	46.68%
299	Mammer Dag	Bajaur	PIL-44	13/Nov/2018	In progress	76.01%
300	Zaga Dherai	Bajaur	PIL-44	13/Nov/2018	Not yet started.	0.00%
301	Girai-II	Bajaur	PIL-44	13/Nov/2018	In progress	46.32%
302	Lar Khar kano	Bajaur	PIL-44	13/Nov/2018	Work stopped	50.16%
303	Bhai Cheena	Bajaur	PIL-44	13/Nov/2018	Not yet started.	0.00%
304	Badi Samoor	Bajaur	PIL-44	13/Nov/2018	Not yet started.	0.00%
305	Umarai-2	Bajaur	PIL-44	13/Nov/2018	Work stopped	1.50%
	Irrigation Water Supply Schemes (Solar)					
306	Tang khata	Bajaur	PIL-44	11-Apr-19	Work stopped	25.00%
307	Khair Abad	Bajaur	PIL-44	11-Apr-19	In progress	90.00%
308	Aman Kot	Bajaur	PIL-44	11-Apr-19	Not yet started	
309	Sham shak (Sadiq abad)	Bajaur	PIL-44	11-Apr-19	Work stopped	25.00%
310	Ghali Shah	Bajaur	PIL-44	11-Apr-19	In progress	90.00%
311	Dherai Tangkhatta	Bajaur	PIL-44	11-Apr-19	Work stopped	25.00%
312	Mulano Killi	Bajaur	PIL-44	11-Apr-19	In progress	90.00%
313	Narrai Shah	Bajaur	PIL-44	11-Apr-19	In progress	85.00%
314	Dag Loe Sum	Bajaur	PIL-44	11-Apr-19	Work stopped	25.00%
315	Bar Kamer	Bajaur	PIL-44	11-Apr-19	In progress	85.00%
316	Kamer Jan	Bajaur	PIL-44	11-Apr-19	In progress	85.00%
317	Umarai-1	Bajaur	PIL-44	11-Apr-19	Not yet started	
318	Dando	Bajaur	PIL-44	11-Apr-19	Work stopped	25.00%
319	Loe Sam	Bajaur	PIL-44	11-Apr-19	In progress	85.00%
320	Shago Chianagai	Bajaur	PIL-44	11-Apr-19	Work stopped	25.00%
321	Earb	Bajaur	PIL-44	11-Apr-19	Work stopped	25.00%
322	Kharai Kamer	Bajaur	PIL-44	11-Apr-19	Not yet started	
323	Girai-I	Bajaur	PIL-44	11-Apr-19	Not yet started	
324	Pacha Killi	Bajaur	PIL-44	11-Apr-19	In progress	90.00%
325	Gafoor Shah	Bajaur	PIL-44	11-Apr-19	Work stopped	25.00%
326	Bar Khalozai	Bajaur	PIL-44	11-Apr-19	Work stopped	25.00%
327	Bar Khar Kano	Bajaur	PIL-44	11-Apr-19	Work stopped	25.00%
328	Dabdaboo	Bajaur	PIL-44	11-Apr-19	Work stopped	25.00%
329	Kausar	Bajaur	PIL-44	11-Apr-19	Not yet started	
330	Jour Qilla	Bajaur	PIL-44	11-Apr-19	In progress	90.00%
331	Mammer Dag	Bajaur	PIL-44	11-Apr-19	Work stopped	25.00%
332	Zaga Dherai	Bajaur	PIL-44	11-Apr-19	In progress	85.00%
333	Girai-II	Bajaur	PIL-44	11-Apr-19	Not yet started	
334	Lar Khar kano	Bajaur	PIL-44	11-Apr-19	In progress	85.00%
335	Bahi Cheena	Bajaur	PIL-44	11-Apr-19	In progress	85.00%
336	Badi Samoor	Bajaur	PIL-44	11-Apr-19	Work stopped	25.00%
337	Umarai-2	Bajaur	PIL-44	11-Apr-19	In progress	85.00%
	Irrigation Water Supply Schemes (Civil)					
338	3003 (Kala Khel-1)	Khyber	PIL-44	-	Not yet started	-
339	3005/3 (Kala Khel-3)	Khyber	PIL-44	-	Not yet started	-
340	3006 (Kala Khel-4)	Khyber	PIL-44	-	Not yet started	-
341	3012 (Madaz Khel)	Khyber	PIL-44	-	Not yet started	-
342	3021/4 (Gadar Durzi Khel)	Khyber	PIL-44	-	Not yet started	-
343	3041 (Mada Khel)	Khyber	PIL-44	-	Not yet started	-
344	3043 (Sama Garhi)	Khyber	PIL-44	-	Not yet started	-
345	3044 (Krapa Aka Khel)	Khyber	PIL-44	-	Not yet started	-
346	3047 (Dobri Talou)	Khyber	PIL-44	-	Not yet started	-
347	3048 (Shalober)	Khyber	PIL-44	-	Not yet started	-
348	3059 (Bara)	Khyber	PIL-44	-	In progress	1%

Architect-Engineer Independent Quality Assurance and Milestone Certification Services for USAID's Federally Administered Tribal Areas Infrastructure and Khyber Pakhtunkhwa Reconstruction Programs (A-E FIP KPRP)
FATA Infrastructure Program (FIP) - List of Projects

As of July 31, 2020

S.No	Project Description	District	PIL/FARA	Date of Work Order	Status	Progress (%age)
349	SK-1 (Shah Kass-1)	Khyber	PIL-44	-	In progress	1%
350	SK-2 (Shah Kass-2)	Khyber	PIL-44	-	In progress	1%
351	3031/2 (Jamal Khel)	Khyber	PIL-44	-	Not yet started	-
352	431/1 (Mastal Khel)	Khyber	PIL-44	-	Not yet started	-
353	433/3 (Khatati Khel)	Khyber	PIL-44	-	In progress	70%
354	435/1 (Kabal Sher)	Khyber	PIL-44	-	Work stopped	30%
355	436/1 (Sur Khel Shah)	Khyber	PIL-44	-	In progress	1%
356	TW #01 (Ajab Talab)	Khyber	PIL-44	-	In progress	1%
357	TW #02 (Shin Drang)	Khyber	PIL-44	-	In progress	79%
358	TW #03 (Mawaz Killi)	Khyber	PIL-44	-	Not yet started	-
359	TW #06 (Sunzala Khel)	Khyber	PIL-44	-	In progress	76%
360	TW #07 (Toheed Abad)	Khyber	PIL-44	-	In progress	38%
361	TW #08 (Kalanga)	Khyber	PIL-44	-	Not yet started	-
362	TW #10 (Sail Khan Aka Khel)	Khyber	PIL-44	-	Not yet started	-
363	TW # 24 (Qazi Zafar kili)	Khyber	PIL-44	-	Not yet started	-
364	/TW # 433/2 (Maseed Khan Killi)	Khyber	PIL-44	-	Not yet started	-
	Irrigation Water Supply Schemes (Solar)					
365	3003 (Kala Khel-1)	Khyber	PIL-44	1-Nov-19	In progress	25%
366	3005/3 (Kala Khel-3)	Khyber	PIL-44	1-Nov-19	In progress	25%
367	3006 (Kala Khel-4)	Khyber	PIL-44	1-Nov-19	In progress	25%
368	3012 (Madaz Khel)	Khyber	PIL-44	1-Nov-19	In progress	25%
369	3021/4 (Gadar Durzi Khel)	Khyber	PIL-44	1-Nov-19	In progress	25%
370	3041 (Mada Khel)	Khyber	PIL-44	1-Nov-19	In progress	25%
371	3043 (Sama Garhi)	Khyber	PIL-44	1-Nov-19	In progress	25%
372	3044 (Krapa Aka Khel)	Khyber	PIL-44	1-Nov-19	In progress	25%
373	3047 (Dobri Talou)	Khyber	PIL-44	1-Nov-19	In progress	25%
374	3048 (Shalober)	Khyber	PIL-44	1-Nov-19	In progress	25%
375	3059 (Bara)	Khyber	PIL-44	1-Nov-19	Not yet started	-
376	SK-1 (Shah Kass-1)	Khyber	PIL-44	1-Nov-19	Not yet started	-
377	SK-2 (Shah Kass-2)	Khyber	PIL-44	1-Nov-19	Not yet started	-
378	3031/2 (Jamal Khel)	Khyber	PIL-44	1-Nov-19	In progress	25%
379	431/1 (Mastal Khel)	Khyber	PIL-44	1-Nov-19	Not yet started	-
380	433/3 (Khatati Khel)	Khyber	PIL-44	1-Nov-19	In progress	25%
381	435/1 (Kabal Sher)	Khyber	PIL-44	1-Nov-19	Not yet started	-
382	436/1 (Sur Khel Shah)	Khyber	PIL-44	1-Nov-19	Not yet started	-
383	TW #01 (Ajab Talab)	Khyber	PIL-44	1-Nov-19	In progress	25%
384	TW #02 (Shin Drang)	Khyber	PIL-44	1-Nov-19	In progress	25%
385	TW #03 (Mawaz Killi)	Khyber	PIL-44	1-Nov-19	In progress	25%
386	TW #06 (Sunzala Khel)	Khyber	PIL-44	1-Nov-19	Not yet started	-
387	TW #07 (Toheed Abad)	Khyber	PIL-44	1-Nov-19	Not yet started	-
388	TW #08 (Kalanga)	Khyber	PIL-44	1-Nov-19	Not yet started	-
389	TW #10 (Sail Khan Aka Khel)	Khyber	PIL-44	1-Nov-19	In progress	25%
390	TW # 24 (Qazi Zafar kili)	Khyber	PIL-44	1-Nov-19	In progress	25%
391	/TW # 433/2 (Maseed Khan Killi)	Khyber	PIL-44	1-Nov-19	Not yet started	-
	Irrigation Water Supply Schemes (Civil)					
392	Said Rehman	Mohmand	PIL-44	-	In progress	12.42%
393	Raees Khan 2047/32	Mohmand	PIL-44	-	In progress	17.60%
394	Shahid Khan 13/2025	Mohmand	PIL-44	-	In progress	3.38%
395	31/2046 (Safi-1)	Mohmand	PIL-44	-	In progress	85.45%
396	2014/26 (Safi-3)	Mohmand	PIL-44	-	Not yet started	-
397	M6/2006 (Prang Ghar-1)	Mohmand	PIL-44	-	In progress	20.23%
398	12 / 20 24 (Baizai)	Mohmand	PIL-44	-	Not yet started	-
399	15 / 2028 (Prang Ghar-2)	Mohmand	PIL-44	-	In progress	0.67%
400	2032 / 19 (Prang Ghar-3)	Mohmand	PIL-44	-	In progress	84.32%
401	3 / MT-3 (Safi-4)	Mohmand	PIL-44	-	Not yet started	-
402	Gul Zada	Mohmand	PIL-44	-	In progress	1.00%
403	Imad Uddin	Mohmand	PIL-44	-	In progress	63.23%
404	M. Zahoor	Mohmand	PIL-44	-	In progress	56.69%
405	M. Hayat	Mohmand	PIL-44	-	In progress	51.30%
406	Zahir Muhammad	Mohmand	PIL-44	-	In progress	41.20%
407	Wisal Muhammad	Mohmand	PIL-44	-	Work stopped	1.00%
408	Faheed Gul	Mohmand	PIL-44	-	In progress	15.00%
409	Faiz Ullah	Mohmand	PIL-44	-	Not yet started	-
410	Ibrar Khan	Mohmand	PIL-44	-	In progress	58.16%
	Irrigation Water Supply Schemes (Solar)					
411	Said Rehman	Mohmand	PIL-44	1-Nov-19	Not yet started	-
412	Raees Khan	Mohmand	PIL-44	1-Nov-19	Not yet started	-
413	Shahid Khan	Mohmand	PIL-44	1-Nov-19	Not yet started	-
414	31/2046	Mohmand	PIL-44	1-Nov-19	Not yet started	-
415	2014/26	Mohmand	PIL-44	1-Nov-19	Not yet started	-

Architect-Engineer Independent Quality Assurance and Milestone Certification Services for USAID's Federally Administered Tribal Areas Infrastructure and Khyber Pakhtunkhwa Reconstruction Programs (A-E FIP KPRP)
FATA Infrastructure Program (FIP) - List of Projects

As of July 31, 2020

S.No	Project Description	District	PIL/FARA	Date of Work Order	Status	Progress (%age)
416	M6/2006	Mohmand	PIL-44	1-Nov-19	Not yet started	-
417	12 / 20 24	Mohmand	PIL-44	1-Nov-19	Not yet started	-
418	15 / 2028	Mohmand	PIL-44	1-Nov-19	Not yet started	-
419	2032 / 19	Mohmand	PIL-44	1-Nov-19	Not yet started	-
420	3 / MT-3	Mohmand	PIL-44	1-Nov-19	Not yet started	-
421	Gul Zada	Mohmand	PIL-44	1-Nov-19	Not yet started	-
422	Imad Uddin	Mohmand	PIL-44	1-Nov-19	in progress	85%
423	M.Zahoor	Mohmand	PIL-44	1-Nov-19	in progress	85%
424	M. Hayat	Mohmand	PIL-44	1-Nov-19	in progress	85%
425	Zahir Muhammad	Mohmand	PIL-44	1-Nov-19	in progress	25%
426	Wisal Muhammad	Mohmand	PIL-44	1-Nov-19	Not yet started	-
427	Faheed Gul	Mohmand	PIL-44	1-Nov-19	Not yet started	-
428	Faiz Ullah	Mohmand	PIL-44	1-Nov-19	Not yet started	-
429	Ibrar Khan	Mohmand	PIL-44	1-Nov-19	Not yet started	-

Annex B Organization Charts

Peshawar Office

PaRRSA/ FATA
Secretariat /A&E
Firms



Legend

- US Home Office based Staff
- Peshawar based Full time Staff
- Remote/Part time staff
- Peshawar based shared staff with MSPKP

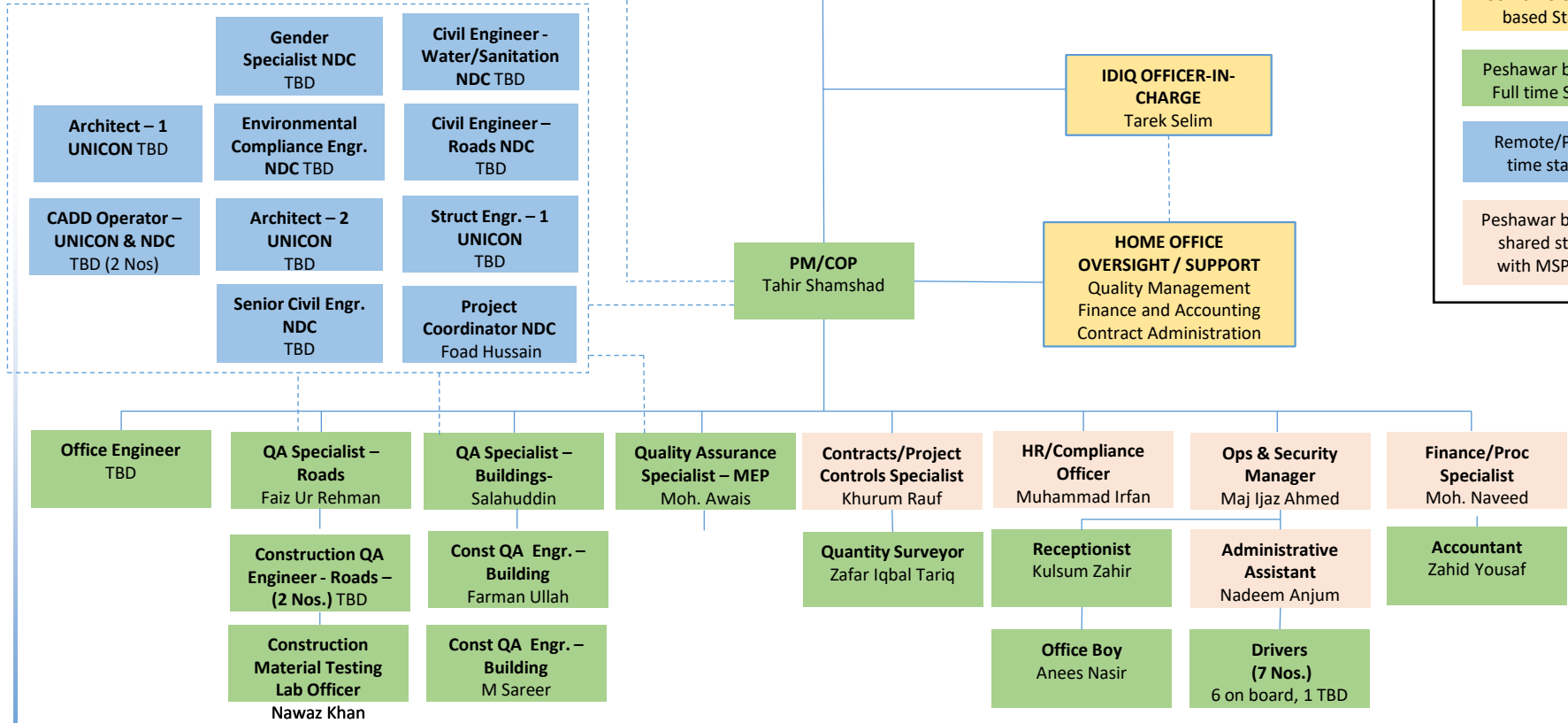

Mingora Office

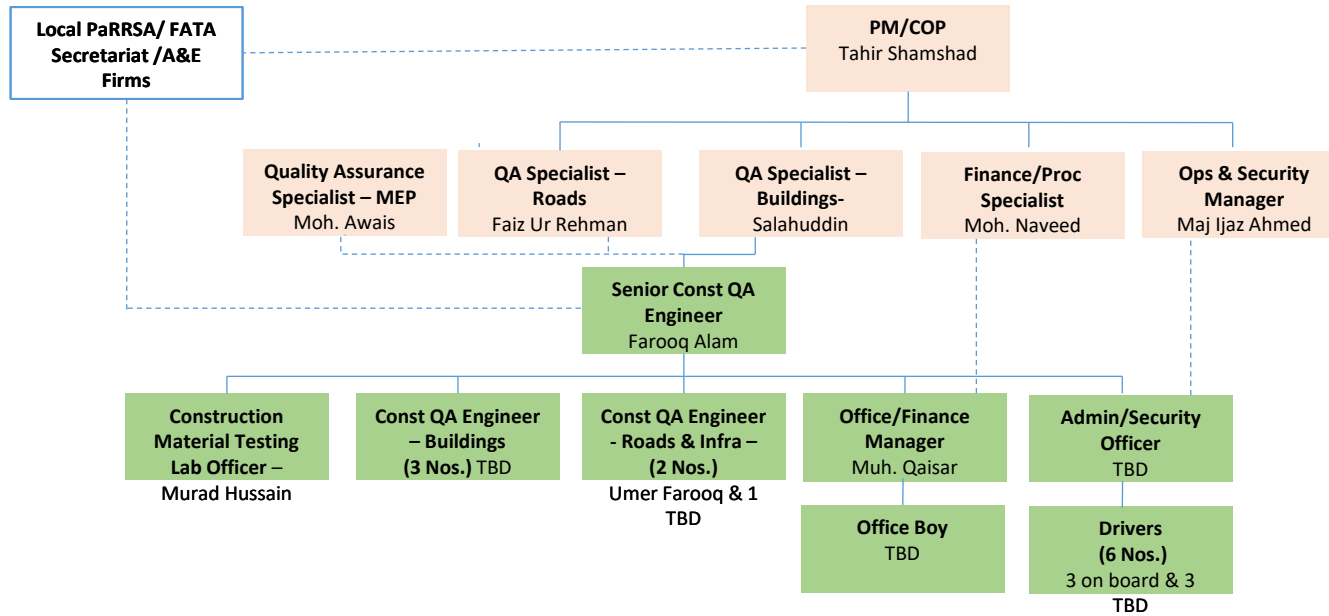
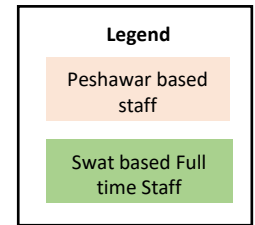

Timir Garah Office

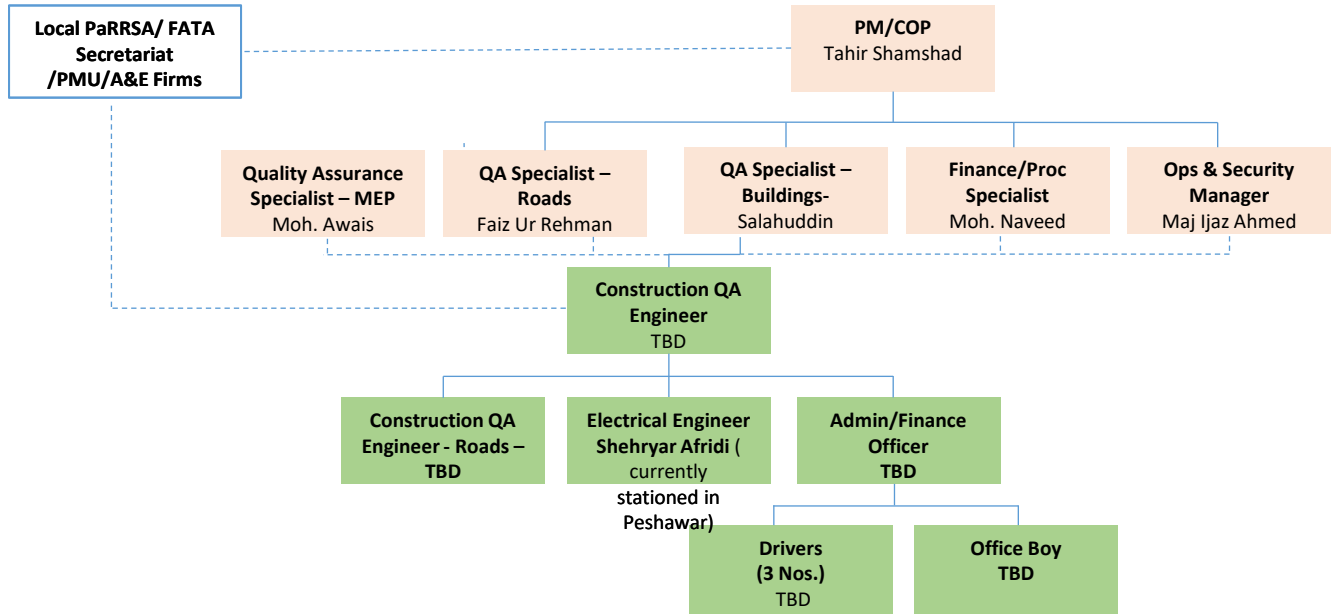
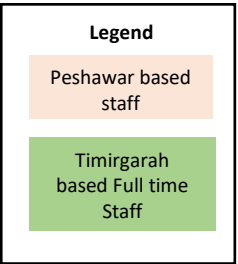

DI Khan Office

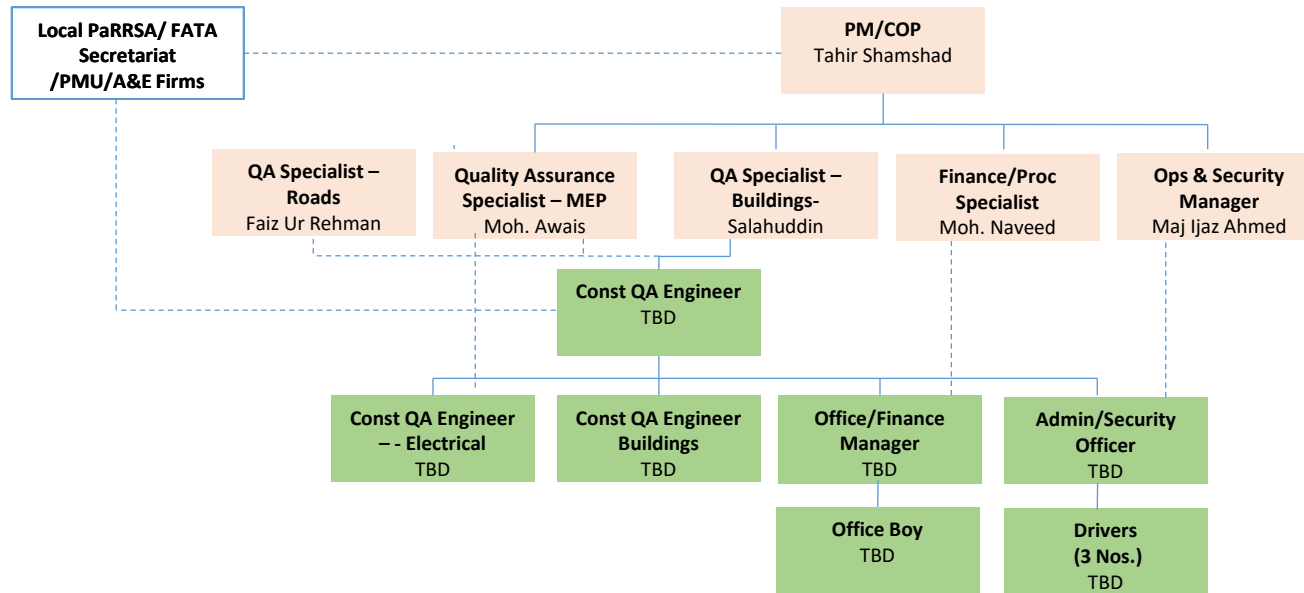
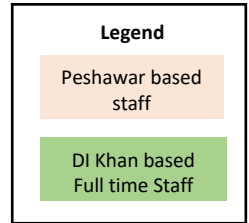

Kurram Agency Office

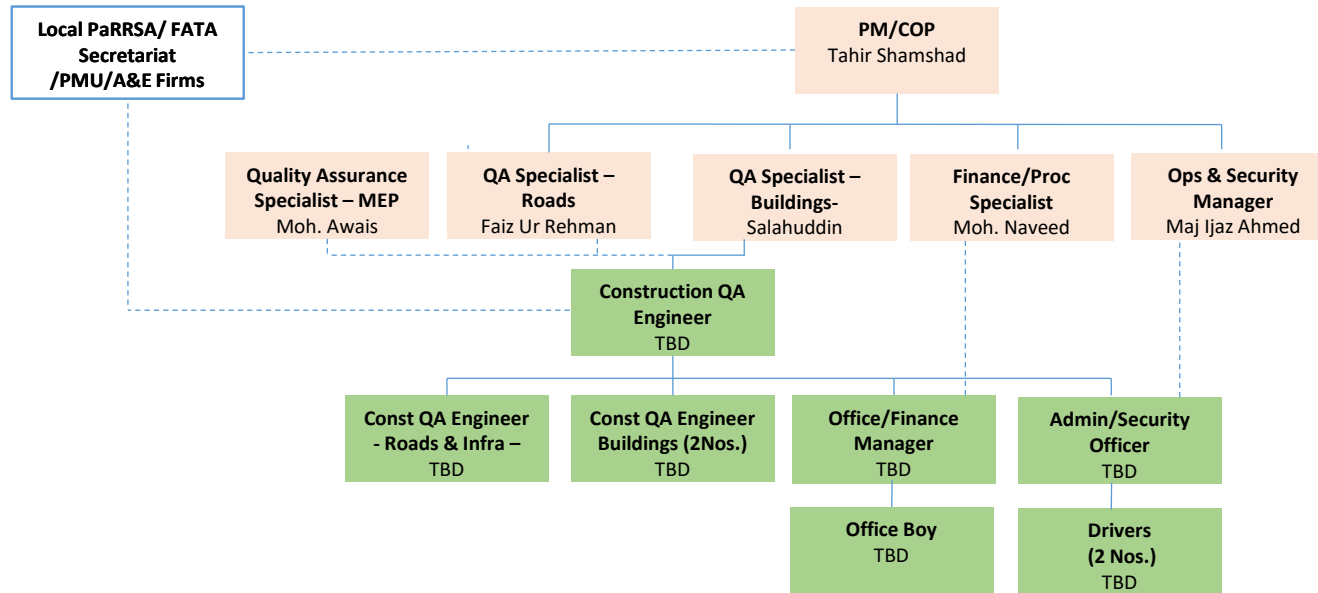
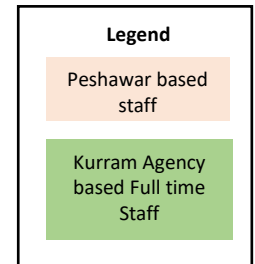

Annex C Site Pictures



Fig. 01. Module M-3-GHS Pashtun Garhi , Nowshera



Fig. 02. Wire mesh fixed at column brick joints-GHS Pashtun Garhi, Nowshera



Fig. 03. Concrete cylinders casted 1:2:4 for Mumty slab-GHS Pashtun Garhi, Nowshera



Fig. 04. Brick facing in progress at Block B - GHSS Akbar Pura, Nowshera



Fig. 05. COP-IQA meeting with site staff at GHS Akbar Pura, Nowshera



Fig. 06. COP-IQA inspecting terrazzo flooring at GHS Akbar Pura, Nowshera



Fig. 07. Electric internal wiring is in progress – GPS Yari Koroona, Peshawar



Fig. 08. Wire Mesh fixing in progress-GPS Yari Korona, Peshawar



Fig. 09. Plastered surface being damaged for locating light points - GPS Yari Koroona, Peshawar



Fig. 10. A view of construction work - GGPS Panam Dheri, Peshawar



Fig. 11. Concrete during pouring is in progress - GGPS Panam Dheri, Peshawar



Fig. 12. Concrete pouring is in progress - GGPS Panam Dheri, Peshawar



Fig. 13. Concreting in progress of OHWT-GPS no.01 Katozai, Charsada



Fig. 14. Paint work in progress at first floor-GPS No.01 Katozai, Charsada



Fig. 15. Plaster in progress at parapet wall-GGPS Sadar Garhi, Charsada



Fig. 16. Marble flooring in progress at 1st floor-GGPS Sadar Garhi, Charsada



Fig. 17. Module M-6H & M4-H (A)-GHS Khesghi Bala, Nowshera



Fig. 18. Brick work and concreting of short columns in progress-GHS Khesghi Bala, Nowshera



Fig. 19. Module M-7 - GHSS No.1 Nowshera Kalan



Fig. 20. Steel fixing in progress at Module M-4B - GHSS Nowshera Kalan



Fig. 21. Module M-3 - GPS Toha, Nowshera



Fig. 22. Marble grinding in progress - GPS Toha, Nowshera



Fig. 23. Module M-3 - GPS Hawaii, Nowshera



Fig. 24. Shuttering for beams/slab in progress at LB - GPS Hawaii, Nowshera



Fig. 25. Module M-3 - GGPS Aman Kot Nowshera



Fig. 26. Pit excavated for earthing -GGPS Aman Kot Nowshera



Fig. 27. View of module M-3-GGPS Maroba, Nowshera



Fig. 28. Concrete surface exhibiting poor workmanship -GGPS Maroba, Nowshera



Fig. 29. Module M-4, M-6 and M-3-GHS Masho Khel, Peshawar



Fig. 30. Honeycombing at M-3 (H) columns-GHS Masho Khel, Peshawar



Fig. 31. Formwork fixing in progress-GPS No.02 Maira Balarzai, Peshawar



Fig. 32. View of Module M-6H-GHS Matani, Peshawar



Fig. 33. View of Module M4-H (B)-GHS Matani, Peshawar



Fig. 34. Rejected brick encircled-GHS Matani, Peshawar



Fig. 35. Painted surface deteriorated above the skirting level-GPS No.01 Yarak, DIK



Fig. 36. Change over and voltmeter were found missing - GPS No.01 Yarak, DIK



Fig. 37. Steel railing for ramp is not stable-GPS No.01 Yarak, DIK



Fig. 38. Steel railings should be strengthened-GPS Bairoon Sharqi, DIK



Fig. 39. Steel grill on parapet wall is broken-GPS Jhoke Umaray Wali, DIK



Fig. 40. Towel rod is broken-GPS Jhoke Umaray Wali, DIK



Fig. 41. View of Modules M-6, M-11, M 13 A, B and C at GGHS No. 1 Mingora, Swat



Fig. 42. Boundary wall works in progress at GGPS Naway Kalay, Swat



Fig. 43. Works in progress at Module M13 B. View of GGPS Bara Bandai, Swat



Fig. 44. External wall pointing works at T-7 of GGPS Daro Maira, Swat



Fig. 45. View of GHS Swegalai, Swat



Fig. 46. Brick work in progress at SF of module M-13 at GGPS Shah Dherai, Swat



Fig. 47. View of the Module M-13 at GGPS Shah Dherai, Swat



Fig. 48. View of the Module T-3 at GPS Pir Patay Qalagai, Swat



Fig. 49. Formwork for truss beam in progress – view of the Module T3 at GPS Pansat, Swat



Fig. 50. T7 roof truss beam formwork along with the external plastering works in progress at GPS Talkar, Swat



Fig. 51. Brick masonry works along with fixing of door and window frames in progress at G/F of T-7 for GPS Chatoria, Swat



Fig. 52. View of the Module T3 at GPS Shofin Chatoria, Swat



Fig. 53. Formwork and rebar work for GF slab in progress for T3 at GPS Fatima, Swat



Fig. 54. Formwork for G/F Beams in progress for M6 (H) GGCMHS THANA, MALAKAND



Fig. 55. Rebar work for F/F columns in progress for U-Shaped Building GGCMHS, Thana Malakand



Fig. 56. G/F slab concrete works completed for U-Shaped Building at GHS Matiltan, Swat



Fig. 57. Commenced rebar work for F/F columns of U-Shaped Building at GHS Utror, Swat



Fig. 58. Construction view of GHS Jan Bhatti, Dir Upper



Fig. 59. A view of GPS Gul Zada Kalay, Malakand



Fig. 60. Brick work was in progress on M-2 Gulzada Kalay, Malakand



Fig. 61. View Fig.62. Three Stud were settling down due to flood in river needs safety measures to protect and rectify the executed work on river Swat



on upstream of the
ver swat

Fig. 64. Direct dumping of clayey material instead of boulders behind the wall. This issue needs to be addressed.

**Architect-Engineer Independent Quality Assurance and Milestone
Certification Services for USAID's Federally Administered Tribal Areas
Infrastructure and Khyber Pakhtunkhwa Reconstruction Programs
(A-E FIP KPRP)**

**U.S. Agency for International Development
Embassy of United States of America
Diplomatic Enclave, Ramna 5
Islamabad
Pakistan**